



WaveGuide - Direction

User Manual

WaveGuide - Direction User Manual

Applicable for product no.
WG-DR40-SS

Version 4.0
17th of May 2016



Radac B.V.
Elektronicaweg 16b
2628 XG Delft
The Netherlands
tel: +31(0)15 890 3203
e-mail: info@radac.nl
website: www.radac.nl



Preface

This user manual and technical documentation is intended for engineers and technicians involved in the software and hardware setup of the non Ex. certified stainless steel version of the WaveGuide Direction.

Note

All connections to the instrument must be made with shielded cables with exception of the mains. The shielding must be grounded in the cable gland or in the terminal compartment on both ends of the cable. For more information regarding wiring and cable specifications, please refer to Chapter 2.

Legal aspects

The mechanical and electrical installation shall only be carried out by trained personnel with knowledge of the local requirements and regulations for installation of electronic equipment.

The information in this installation guide is the copyright property of Radac BV.

Radac BV disclaims any responsibility for personal injury or damage to equipment caused by:

- Deviation from any of the prescribed procedures.
- Execution of activities that are not prescribed.
- Neglect of the general safety precautions for handling tools and use of electricity.

The contents, descriptions and specifications in this installation guide are subject to change without notice. Radac BV accepts no responsibility for any errors that may appear in this user manual.

Additional information

Please do not hesitate to contact Radac or its representative if you require additional information.

Contents

Preface

Introduction	1
1 Radar positioning and installation	3
1.1 Safety notes	3
1.2 Positioning	4
1.3 The point array	7
1.4 The line array	9
1.5 The triangle array	10
2 Wiring	11
2.1 WaveGuide radar	11
2.2 WaveGuide processing unit	12
2.3 Three cable connection	13
2.4 One cable connection	14
2.5 Separate power supply for the radars	15
3 WaveGuide system commissioning	16
Step 1. Connect the WaveGuide processing unit to a computer	17
Step 2. Become an authorized user	18
Step 3. Configuration	18
Step 3.1: Set system date and time	18
Step 3.2: Adjust network settings	19
Step 3.3: Sensor configuration	20
Step 4: Perform a system check	23
Step 4.1: Check the System Information page	23
Step 4.2: Check the reflection diagrams	24
Step 4.3: Check measurements	24
Step 5: Configure the distribution of data	24
4 Using the system	27
4.1 Calculated parameters	27
4.2 Data logging	27
Appendix 1: System parameters	29
Appendix 2: System specifications	33

Introduction

The principle of operation of a WaveGuide Direction is based on the synchronized measurements of sea elevation (heave) at three different spots on the surface of the water. Using these measured elevations, the water surface slopes are calculated in two perpendicular horizontal directions. Then the correlations between the calculated slopes and the measured heave values are used to determine the wave directional information.

The three radar sensors are standard WaveGuide Height&Tide radar sensors that are connected to a WaveGuide Direction processing unit. Each WaveGuide radar measures the distance between the sensor antenna and the water surface. The WaveGuide processing unit takes care of the data handling (synchronized measurements, processing, distribution and presentation). The WaveGuide processing unit also facilitates commissioning and (remote) servicing of the system. All facilities are accessible via the built in web-server (running on the WaveGuide processing unit).

The WaveGuide radar sensors are available in two versions:

- A standard Ex. certified version.
- A non Ex. certified stainless steel version, where the antenna and electronics are built into one stainless steel compact unit. The antenna and electronics are the same in both versions but the stainless steel version is easier to handle due to its compact size.

This manual describes the non Ex. certified stainless steel version of the WaveGuide Direction.

Warning

Do not use the instrument for anything else than its intended purpose.

This manual consists of 4 chapters. Chapter 1 specifies the criteria of radar sensor positioning for optimal quality of measurements. Chapter 2 illustrates the mounting and installation procedure. Chapter 3 describes the commissioning of the system via the user interface. Chapter 4 explains data processing, data presentation and data distribution within the system.

Please refer to Appendix 1 for a list of measured and calculated parameters. And to Appendix 2 for specifications, information about certification and environmental conditions applicable to the WaveGuide Direction.

Chapter 1

Radar positioning and installation

1.1 Safety notes

The personnel installing the WaveGuide system must have basic technical skills to be able to safely install the equipment. When the WaveGuide system is installed in a hazardous area, the personnel must work in accordance with the (local) requirements for electrical equipment in hazardous areas.

Caution

Modification to the instrument may only be carried out by trained personnel that are authorized by Radac BV. Failure to adhere to this will invalidate the approval certificate.

Warning

In hazardous areas it is compulsory to use personal protection and safety gear such as: hard hat, fire-resistive overall, safety shoes, safety glasses and working gloves.

Avoid possible generation of static electricity.

Use non-sparking tools and explosion-proof testers.

Make sure no dangerous quantities of combustible gas mixtures are present in the working area.

Never start working before the work permit has been signed by all parties.

Warning

Make sure that all power to the instrument is switched off before opening the covers of the WaveGuide radar. Failure to do so may cause danger to persons or damage the equipment.

All covers of the WaveGuide radar must be closed before switching on the power.

1.2 Positioning

For obtaining the best results from each WaveGuide radar sensor a number of positioning criteria must be taken into account:

- It is advised to choose a mounting position such that the WaveGuide radar beam is free of large reflecting obstacles (the beam of the F08 antenna can be approximated to a conical shape having a 5° [deg] half top angle as shown in Fig. 1.1). The minimum horizontal distance between a radar and any obstacle in the beam's path should be at least 10% of the vertical distance between the radar and the obstacle. This does not only include horizontal objects in the beam's path but also vertical structures.
- Any structure that the WaveGuide radar sensors are mounted to might have some influence on the wave flow around it. Hence, it is advised to mount the radars at a position facing the mean wave direction so that the radars can measure the least disturbed water surface.
- The reference level for the mounting height of the radars is shown in Fig. 1.2.
- A vertically mounted radar (0° [deg] tilt angle) results in optimal performance. But if necessary the WaveGuide radar can be mounted with a maximum tilt angle of 15° [deg] (tilted to face the direction away from the structure it is mounted on).

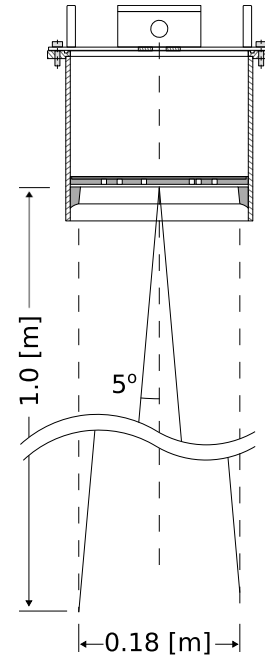

Figure 1.1: The 5° [deg] half top angle of the F08 antenna beam.

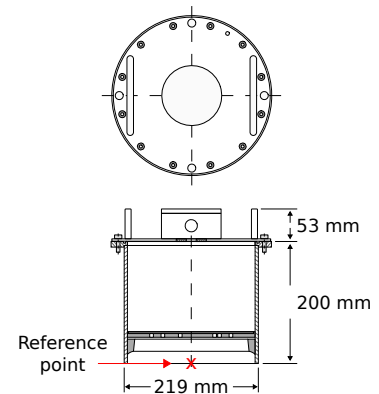

Figure 1.2: The reference point for mounting height measurement and radar position.

The working principle of the WaveGuide Direction is the measurement of surface elevation at three different positions using an array consisting of three radars. The array design criteria are:

- The footprints (measurement points) of the three radars on the sea surface must form a triangle.
- To obtain directional information of the same quality for all wave directions an equilateral triangle is preferable but not critical.
- The measurement of wave directional parameters is optimal for wave lengths that are 3 to 30 times the array size (distance between the center of two radar footprints). For example, if the dominant wave periods are between 3 and 10 [sec] long (wave lengths from 15 to 150 [m] long). Then for such waves, a radar array size of 5 [m] is optimal.

To allow the WaveGuide Direction to be installed in various locations it is designed to be mounted in one of three array configurations. All three configurations allow for the radar array footprint to form an equilateral triangle on the sea surface at mean water level.

- The point array, where the three radars are mounted on a single frame, is the recommended configuration in most situations. One radar is looking vertically downwards. The two other radars are tilted with an angle between 10 and 15 [deg] from vertical in the direction away from the downward looking radar. In this case the size and position of the array footprints depends on the choice of tilt angle and the vertical position of the radars (height above actual water level).
- The line array, where the mounting positions of the three radars form a straight line. The two outside radars are mounted at zero inclination angles and the middle radar is tilted with an angle between 10 and 15 [deg] in a direction perpendicular to the line the radars are mounted on. In this case the size and position of the array footprints depends on the mounting position, the tilt angle and the vertical position of the radars (height above actual water level).
- The triangle array, where the mounting positions of the three radars form a triangle and all three radars are mounted at a zero inclination angle (resulting in optimal performance). In this case the size and orientation of the array footprints are determined only by the horizontal positions of the radars.

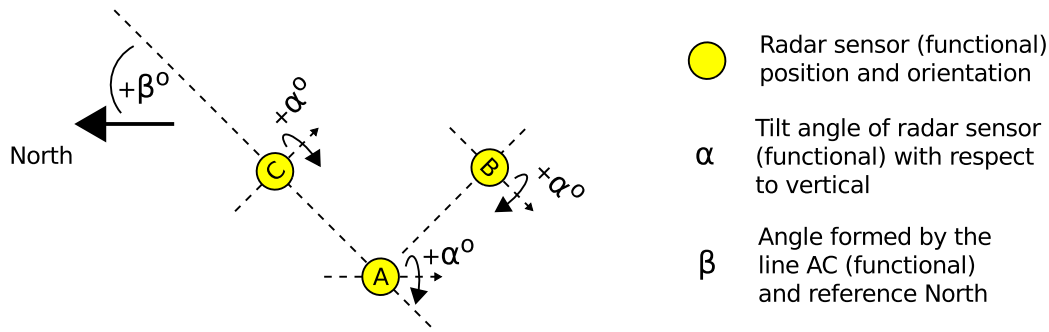

Figure 1.3: Definitions for WaveGuide Direction systems.

The proper installation of a WaveGuide Direction array of radars requires understanding the following naming conventions and standards:

- Each of the three radars is given a functional name (A, B or C). By default the radar connected to port Sensor 1 on the processing unit is related to the function of radar A, Sensor 2 to radar B and Sensor 3 to radar C. If necessary it is possible to adjust these relations with the user manual.
- By definition, radar B will always be positioned on the right side of the line A-C, or in the case of a line array on the line A-C.
- The positions of radars A and C define the array orientation with respect to the reference North.
- When specifying a tilt angle for radar B and C, the tilting direction will be aligned with the position of radar A and the tilt angle will be positive when tilting away from A. (Right hand rule in Fig. 1.3.)
- When specifying a tilt angle for radar A the tilting direction will be aligned with the center between positions B and C and positive in the direction of the center between B and C. (Right hand rule in Fig. 1.3.)
- On the "Configuration -> Sensor" page of the web-interface the following parameters can be found (more information about accessing and using the web-interface is available in Chapter 3):
 - Distances between radars A, B and C.
 - The angle from the reference North to A to C.
 - Relation between the radar A, B and C (functional) and the physical radars connected to the ports Sensor 1, Sensor 2 and Sensor 3.
 - The configuration parameters and reflection diagrams of the selected radar.

1.3 The point array

The point array has proven to be an easy to install configuration that requires the smallest amount of space on the supporting structure. The correct installation requires the radars to be installed in a counter clockwise manner with radar A installed vertically and B and C at a fixed tilt angle.

Upon request, Radac can provide a standard mounting frame (product no. WG-MD-SS) that allows for easy and accurate mounting of the system (Fig. 1.6). The mounting frame can be used to mount the three radars together while allowing the vertical mounting of one radar and the tilted mounting of two radars (tilted to 15 [deg] from vertical). This results in an array footprint size that is approximately 25% of the mounting height. Using the array design criteria it can be concluded that this configuration is optimized for measuring directional wave parameters for wave lengths that are 0.75 to 7.5 times the mounting height. For example, a mounting height of 10 [m] is optimal for wave lengths in the range from 7.5 to 75 [m] (wave periods from 2.2 to 7 [sec]). While a mounting height of 25 [m] is optimal for a wave length range from 18.75 to 187.5 [m] (wave periods from 3.5 to 11 [sec]).

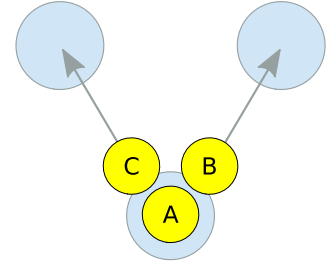

Figure 1.4: Top view of the three radar positions labeled A,B and C in an anticlockwise sequence. In this case the labels apply to the physical radars and their functional definitions.

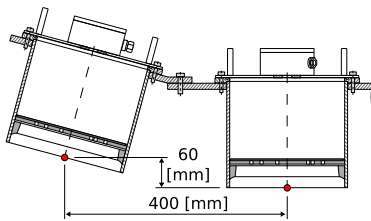

Figure 1.5: Side view of point array mounted on a standard mounting frame (product no. WG-MD-SS).

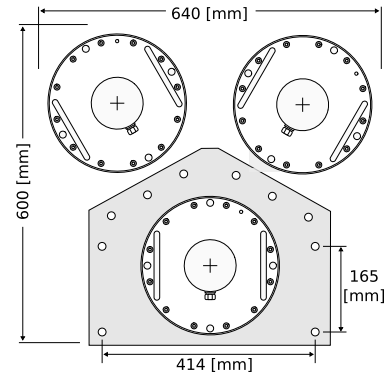

Figure 1.6: Top view of a point array installation mounted on a standard mounting frame (product no. WG-MD-SS).

Installation

The optional mounting frame (product no. WG-MD-SS) consists of three parts connected to each other by bolts. The mounting frame should be installed on two horizontal beams (the horizontal beams are not included in the mounting frame package). Figure 1.6 shows the required positions of the mounting holes along the horizontal beams. Note: when designing and producing the horizontal mounting beams, enough horizontal distance should be left between the radars and the structure they are mounted to. That is, to prevent reflections (as explained in the beginning of this chapter). If the customer chooses to design and manufacture a frame, the centers of the mounted radar sensors must form an equilateral triangle. When installing the radar array it is advised to first install the mounting frame, and secondly position the three radars.

Radar sensor	A	B	C
Tilt angle [deg]	0	15	15
Min. Signal [dB]	20	5	5

Table 1.1: Advised sensor settings specific to a point array.

1.4 The line array

In some cases it can be decided to mount the three radars in line with each other, for example when mounting them to the railing of an offshore platform. This installation is called a line array. In this case the central radar needs to be tilted to obtain a triangular reflection footprint, which is illustrated in Fig. 1.7. In a line array, the tilting definitions (Fig. 1.1) require that radar A is positioned between radar B and C. This allows tilting radar A away from the line B-C and by doing so forming a triangle with the radar foot prints on the water surface. The direction of the radar tilt angle is defined with the right hand rule as shown in Fig. 1.7. It is advised to select non-tilted radar B or C as the "heave source", which is the source of data for calculating the non-directional wave parameters.

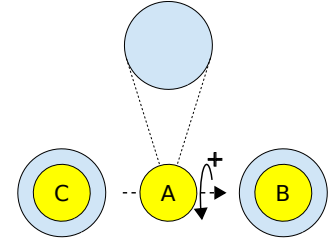

Figure 1.7: Top view of the three radars labeled A, B and C.

A mounting plate can be used to fix each radar to two horizontal beams at the desired location (an example sketch of such a plate is given in Fig. 1.9). Upon request, Radac can supply such a mounting plate (product no. WG-MP-SS). During installation it is advised to install the mounting plate first and secondly install the radar.

Upon request, Radac can supply an optional frame (product no. WG-MH-SS) that allows for mounting a radar at angles 0, 5, 10, 15 and 20 [deg] with the horizontal plane shown in Fig. 1.8). Each frame includes a mounting plate.

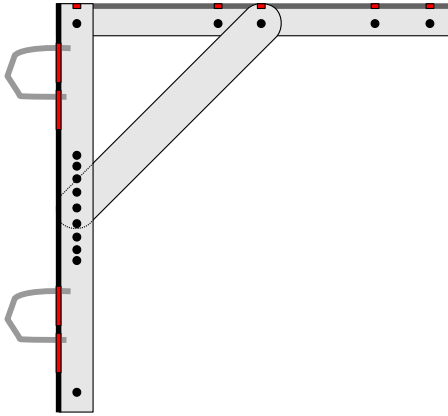

Figure 1.8: Optional frame that allows mounting of the radar at different angles (product no. WG-MH-SS).

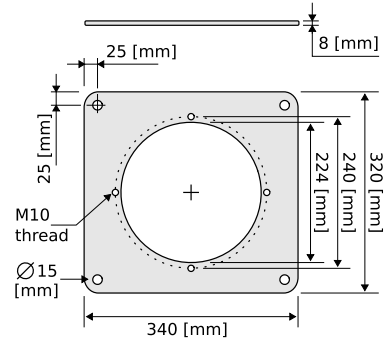

Figure 1.9: Optional mounting plate for an non Ex. certified WaveGuide Radar (product no. WG-MP-SS).

Radar sensor	A	B	C
Tilt angle [deg]	15	0	0
Min. Signal [dB]	5	20	20

Table 1.2: Advised sensor settings specific to a line array.

1.5 The triangle array

The triangle array consists of three radars placed with no any tilt angle, typically about 3 to 6 meter apart. It can be challenging to find a good mounting position for the triangle array on an offshore platform. On the other hand, from the perspective of retrieving the strongest radar reflections, this is the optimal configuration for large mounting heights (above 45m).

As with the other array configurations, radars A, B and C are defined by the port the radar is connected to on the processing unit. The mounting positions of radars A, B and C must be anticlockwise when looking from above (as shown in Fig.1.10). The user-interface allows the user to customise the used configuration.

A mounting plate can be used to fix each radar to two horizontal beams at the desired location (an example sketch of such a plate is given in Fig. 1.11). Upon request, Radac can supply such a mounting plate (product no. WG-MP-SS). During installation it is advised to install the mounting plates first and secondly install the radars.

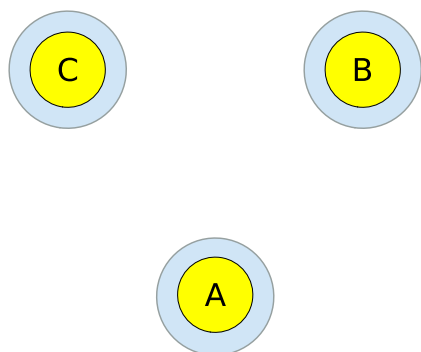

Figure 1.10: The three radar positions are numbered A,B and C in an anticlockwise sequence.

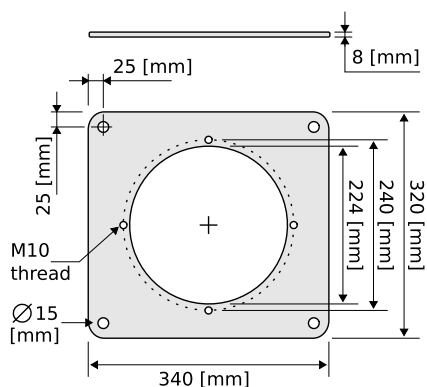

Figure 1.11: Optional mounting plate for a non Ex. certified WaveGuide Radar (product no. WG-MP-SS).

Radar sensor	A	B	C
Tilt angle [deg]	0	0	0
Min. Signal [dB]	20	20	20

Table 1.3: Advised sensor settings specific to a triangle array.

Chapter 2

Wiring

2.1 WaveGuide radar

A cable gland (IP68-10bar and IP69K certified) is supplied with each WaveGuide radar for use on the terminal compartment as a watertight cable entry point. The supplied gland allows the installation of insulated cables from 8 to 15 [mm] in diameter.

In the terminal compartment there is one five pole connector as shown in Fig. 2.1. The connector is used to connect the RS485 data wires (poles labeled with both A, B, GND and 1, 2, 3) and supply power to the radar (poles labeled + and -).

It is advised to use three separate cables to connect the radar sensors to the processing unit (one cable per radar), because this removes the need for a junction box. It is also possible to use a single multicore cable, which is divided at a junction box to connect the three radars. Both methods are explained in the following sections.

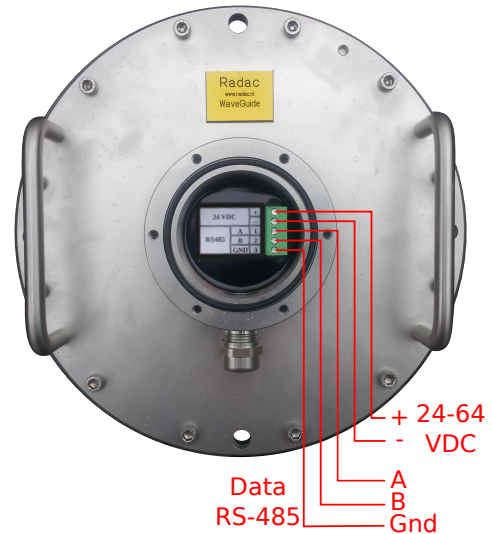

Figure 2.1: Terminal compartment and connections.

Warning

Improper wiring can damage the radar's communication board. Always check that the + and - 24-64VDC is applied to the right terminals before plugging in the connector!

Warning

Safety depends on proper grounding of the radar sensor case. Check the resistance of the ground connection directly after installation. The measured ground resistance shall be below the maximum prescribed by local grounding requirements.

2.2 WaveGuide processing unit

For ease of use, the connector poles common between the WaveGuide processing unit and radars are marked using the same labeling symbols.

Warning

It is of utmost importance to keep in mind the positions of the installed WaveGuide radars with respect to the chosen array type when connecting the radars to the processing unit.

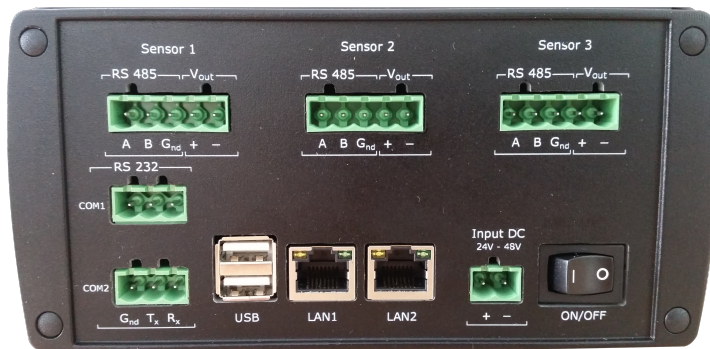

Figure 2.2: Connector panel on the WaveGuide processing unit.

In addition to the connectors labelled as Sensor 1, Sensor 2 and Sensor 3, used for connecting the WaveGuide radars, the connector panel of the WaveGuide processing unit includes the following connectors:

- COM1: Serial port for RS-232 data output.
- COM2: Serial port for RS-232 data output.
- USB: For connecting a USB data storage.
- LAN ports: Ethernet access to the processing unit.
- Input DC: For supplying the system with 24 to 48V power.

When the radar is powered through the processing unit, then the power supply for the processing unit must be 24-48 [VDC] and capable of providing at least 24 Watt. Please do take into account the voltage drop due to wire resistance between the processing unit and the radar, the radar must at all times receive more than 21.0 V. For this reason, to be sure to stay within the limits, at longer distances it is advised to use a 36V or 48V power supply. The power feed-through to the WaveGuide radar is controlled by the power switch on the WaveGuide processing unit.

2.3 Three cable connection

Each cable between the processing unit and a radar, must be a shielded five wire cable with at least one twisted-wire-pair. The length of each cable can not exceed 1200 [m]. The cable shielding must be connected to ground at both ends of the cable. Since there can be a potential difference between the ground at the radar sensor side and the ground at the processing unit side, a capacitor (10 to 100 [nF]) should be used on one side of the cable between its shield and the ground.

The twisted-wire-pair is used for the RS-485 communication link (pins labeled 1 and 2). RS-485 transceivers use differential signals and need a third wire to provide a reference common voltage to allow for the interpretation of the differential signal (pin labeled 3). Without this common reference, a set of transceivers may incorrectly interpret the differential signal.

The remaining two wires out of the five wires in a cable are used for supplying power to the radar (pins labeled + and -).

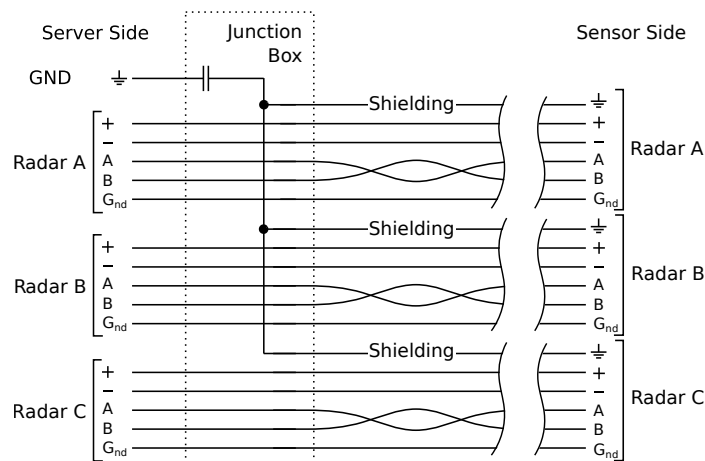

Figure 2.3: The three cable connection diagram between the WaveGuide processing unit and radars when the radars are powered from the processing unit.

2.4 One cable connection

When it is more convenient to use one cable to connect all three radars to the processing unit (for example, when the one-point array configuration is used). The cable used must be a shielded, nine wire cable with at least three twisted-wire-pairs. The length of the cable can not exceed 1200 [m]. The cable shielding must be connected to ground at both ends of the cable. Since there can be a potential difference between the ground at the radar side and the ground at the processing unit side. A capacitor (10 to 100 [nF]) should be used on one side of the cable between its shield and the ground.

The twisted-wire-pairs are used for the RS-485 communication links (pins labeled 1 and 2). RS-485 transceivers use differential signals and need a third wire to provide a reference common voltage to allow for the interpretation of the differential signal (pin labeled 3). Without this common reference, a set of transceivers may incorrectly interpret the differential signal. It is sufficient to use one wire to connect the reference common voltage pins (labeled 3) of all three radars to the reference common voltage pins (labeled 3) of the three connectors on the processing unit side (please note that all reference common voltage pins on the processing unit side and on the radar side must be connected to the reference common voltage wire).

The remaining two wires are used for power and those can be connected to any of the radar connectors (+ and - pins) on the WaveGuide processing unit side. On the side of the radars a terminal box must be used to split the two power wires, the reference common voltage wire and the cable shielding to connect the 3 radars.

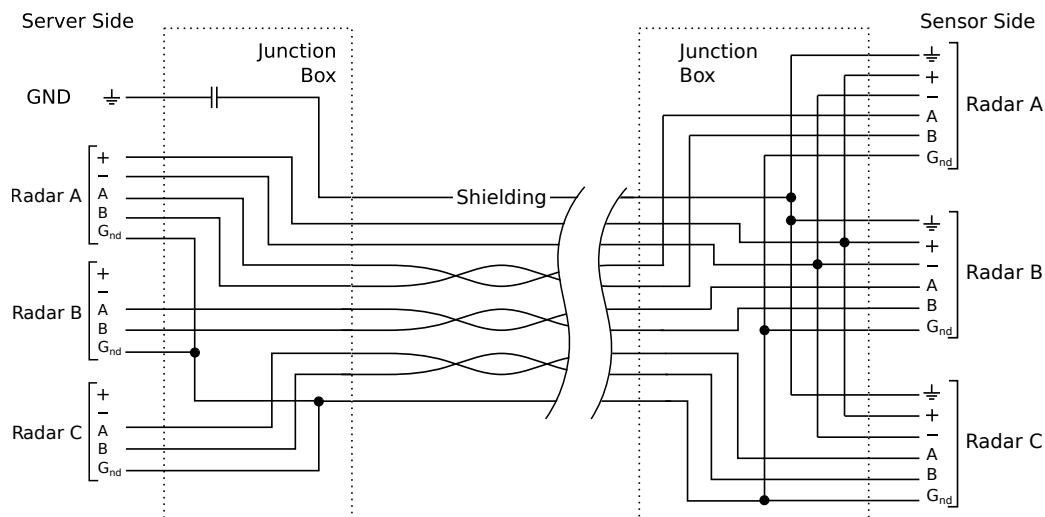

Figure 2.4: The one cable connection diagram between the WaveGuide processing unit and radars when the radars are powered from processing unit.

2.5 Separate power supply for the radars

In some cases it is more convenient to use a separate power supply to power the radar sensors rather than supplying them with power from the processing unit side. In that case a 24-64 [VDC] power supply can be used on the radar side to supply them with a total of 18 [Watt] of power.

If a separate power supply is used for the radars, then the single cable or the three cables used to connect the processing unit to the radars do not need the extra two wires per cable for power. Hence, in the one cable solution seven wires will be sufficient and in the three cable solution three wires per cable will be sufficient.

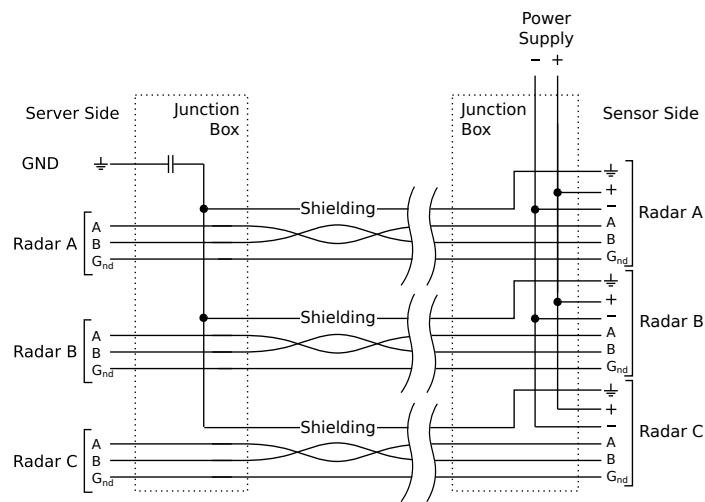

Figure 2.5: The three cable connection diagram between the WaveGuide processing unit and radars when the radars are powered from a separate source.

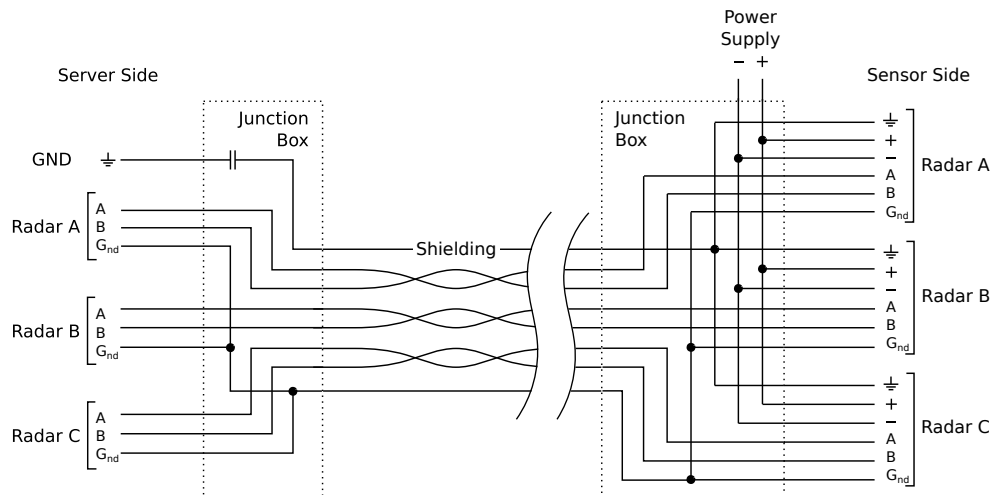

Figure 2.6: The one cable connection diagram between the WaveGuide processing unit and radars when the radars are powered from a separate source.

Chapter 3

WaveGuide system commissioning

With all the wiring in place as described in the previous chapter, the processing unit can be configured using the following steps (explained in the current chapter):

1. Connect the WaveGuide processing unit to a computer.
2. Become an authorized user.
3. Configure the system.
4. Perform a system check.
5. Configure the distribution of data.

The display on the processing unit shows system information and measured parameters and is controlled using the buttons on the front:

- Left and right: To switch between groups.
- Up and down: To switch between items within each group.
- OK: To confirm mounting and unmounting of USB data storage.

The processing unit display contains the following groups and items:

- Parameters
 - Scrolls through selected parameters (Appendix 1, Table 1)
- Network
 - Host name
 - IP address
- System information
 - Date and time
 - Uptime
 - Software version
- USB storage (only appears when USB device is connected)
 - State
 - Mount USB disk?/ Unmount USB disk?

Step 1. Connect the WaveGuide processing unit to a computer

Once the WaveGuide processing unit is connected to a Local-Area-Network, communication with the WaveGuide processing unit can be done via the available web-interface (Fig. 3.1). For this purpose any web browser with JavaScript enabled can be used.

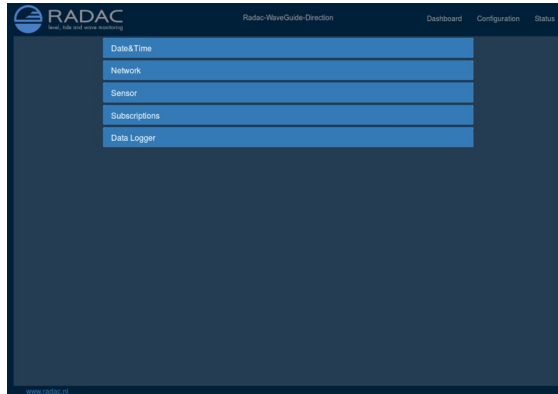

Figure 3.1: The web-interface of the WaveGuide processing unit.

Note

A computer can be connected to the WaveGuide processing unit directly using a network cable (a crossover cable is not required).

By default, during startup the WaveGuide processing unit tries to obtain an IP-address by searching the Local-Area-Network for a DHCP server. If a DHCP server is not found, the WaveGuide processing unit will use the default IP-address 192.168.111.71.

When the WaveGuide processing unit completes the startup process, its IP-address can be found via the LCD display (it can take up to 5 minutes for the IP-address to appear). To view the IP-address, scroll through the menu using the left and right buttons until network information is displayed and then use the up and down buttons to switch between displaying the Host-Name and the IP-address.

An other way of locating the system in a network is by making use of the installed Zeroconf client. Using a Zeroconf browser makes it easy to find the WaveGuide system.

To access the web-interface, type the IP-address indicated on the LCD display in the address line of your web-browser (e.g. 192.168.111.71). Note, that your computer must be on the same IP-address subnet as the WaveGuide processing unit that you are trying to connect to.

The WaveGuide processing unit homepage contains three main sections (Dashboard, Configuration and Status) as listed in Table 3.1.

Link	Description
Dashboard	Visualisation of the measured data.
Configuration	Changing the settings and configuration of the system.
Status	System state overview and general information.

Table 3.1: Description of processing unit main sections.

Step 2. Become an authorized user

To modify the WaveGuide system's configuration you need to be an authorized user. Therefore, an authorization dialogue will appear when the user enters the configuration page.

The authorization will be valid for a duration of 30 minutes. However, the web browser may store the login name and password. In that case, the authorization data will be submitted automatically by the browser without a pop-up dialog. The default login password is "radac".

After successful authorization, the user can view and change settings. After submitting any new settings a reboot dialog will appear. The settings will not be effective until the WaveGuide processing unit is rebooted.

Step 3. Configuration

The configuration page contains five sections as listed in Table 3.2.

Link	Description
Date&Time	For viewing and setting the system time.
Network	For viewing and changing the network settings.
Sensor	For viewing and changing the sensor specific settings and for viewing reflection diagrams.
Subscriptions	To set up data export over the serial ports or over the network.
Data Logger	To log data on a USB drive.

Table 3.2: Description of configuration page sections.

Step 3.1: Set system date and time

In order to ensure an accurate timestamping of the data, the WaveGuide processing unit runs an ntp time service to automatically correct its system time to UTC time. For the ntp service to work, the system needs to be connected to the Internet, as it needs to be able to reach its default ntp servers.

In the case that the ntp servers can not be reached, it is possible to manually set the system date and time using the "Date&Time" menu (Fig. 3.2). Adjusting the date and time while the ntp service is running is not possible as the time will be automatically corrected back to UTC time. The date and time are kept by an on-board clock. Please be aware that such on-board clocks are not highly accurate and can drift over the years while the system is used.

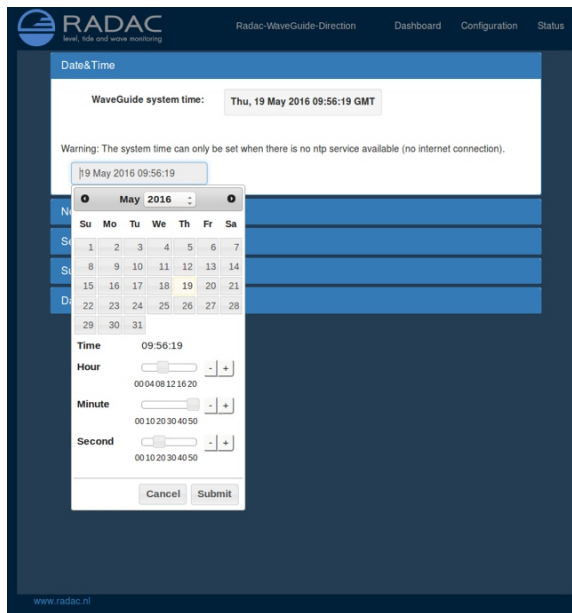

Figure 3.2: Setting the system time and date.

If the WaveGuide system is not connected to the Internet but instead connected to a local network that includes a time server, then the processing unit can be adjusted to synchronize time and date with the local time server. For more information regarding such an adjustment please contact Radac.

Step 3.2: Adjust network settings



Figure 3.3: Adjusting the network settings.

The default IP-address can be modified via the web-interface (Fig. 3.3). It is advised to use the default setting, to automatically obtain the network settings from a DHCP server, and assure from the side of the DHCP server that the system will receive the same IP-address

at all times. This setting provides the easiest setup and ensures the correct settings for the local network.

To ensure an accurate system time, the WaveGuide processing unit is by default configured to use an ntp time service. For this service to work, a connection to the Internet is necessary.

Configuring the use of a static IP could disable the NTP service when the system is not able to reach the default nameserver (8.8.8.8).

Step 3.3: Sensor configuration



Figure 3.4: Adjusting the network settings.

The WaveGuide Direction is designed with a high level of flexibility in mind, to apply to every possible mounting situation. The sensor menu allows the configuration of those parameters that are specific to the sensor installation (Fig. 3.4).

During the process of cabling and installation it is important to accurately keep track of which radar sensor is connected to which port on the processing unit. To avoid confusion it is advised to always connect radar A to the port labeled as sensor 1, radar B to port sensor 2 and radar C to port sensor 3.

In the box labelled as "Distance [cm]" fill in the distances between the radar reference points (see Fig. 1.2 for the radar reference point). Next fill in the "Orientation [deg]", defined by the angle from the vector pointing to the North to the line A-C (from radar A to radar C). The "preview geometry" field to the right, automatically generates an illustration in topview of the array configuration. The geometry preview includes the approximated radar reflection footprints based on the parameters provided (see Fig. 3.5).

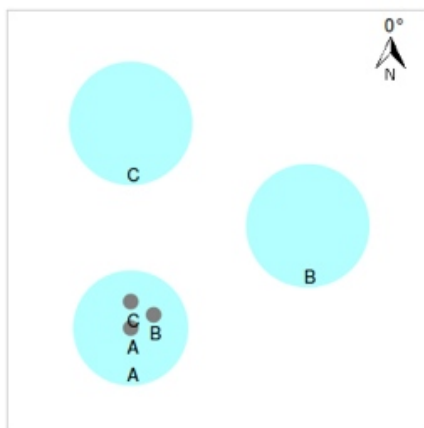

Figure 3.5: Preview of the array orientation based on user input.

The mounting height above the reference water level, and possibly a number of other parameters, needs to be set for each specific mounting location. This can be done in the configuration table that is shown in Fig. 3.6.

Radar sensor	A	B	C
Processing unit port	sensor1	sensor2	sensor3
Mounting height [cm]	1000.0	1000.0	1000.0
Tilt angle [deg]	0.0	15.0	15.0
Max. Range [m]	75.0	75.0	75.0
Min. Range [m]	2.0	2.0	2.0
Min. Signal [dB]	20.0	5.0	5.0
Sensor Type:	Stainless steel	Stainless steel	Stainless steel
Heave Source	<input checked="" type="radio"/>	<input type="radio"/>	<input type="radio"/>
Reflection diagrams	Plot	Plot	Plot

Figure 3.6: Setting sensor parameters (changes only take effect after the system is rebooted).

Processing unit port

The first item in the table, the processing unit port, allows modification of the relation between the ports to which the radars are connected and the functional name that is given to the radars (A, B or C). To avoid confusion, it is advised to leave this setting unchanged. Yet in the case were an installation error is discovered after leaving the system's location this can be a helpful option to correct the installation from the shore.

Mounting height

The mounting height is defined as the height of a radar above the reference water level in [cm]. The reference point for measuring the height of each radar is the lower-side of the radar sensor case (as shown in Fig. 1.2). By default, the mounting height is set to zero [cm].

Tilt angle

The tilt angle, or the angular deviation from the vertical at which the radar is mounted, is measured in degrees. For the point array, it is used to tilt radars B and C away from radar A and obtain a favourable radar-footprint-triangle. In the triangle array, all 3 radars have a tilt angle of 0 [deg]. While for the line array, only radar A will need to have a tilt angle applied (as explained in Chapter 1).

Max. Range

The range maximum is the maximum distance (in [m]) at which the sensor will detect the water level. In general there is no need to modify this parameter. Yet in some situations it is advised to set this parameter to a value lower than two times the distance from the radar to the lowest expected water level. This is to avoid detecting multiple echoes of the same measurement sweep.

Min. Range

The range minimum" is the minimum distance (in [m]) at which the sensor will detect the water level. This parameter is used to avoid spurious measurements and should be set depending on the installation location. If there are any nearby surfaces that can reflect the radar signal the range minimum should be set to a value higher than the distance to those reflecting surfaces. The range minimum" parameter should not be lower than 2 [m] to avoid interference with the internal reflection in the radar antenna.

Min. Signal

The signal minimum is the lower limit for the signal power that will be considered in water level measurements. This parameter should be set to 20 [dB] in the case of a vertically mounted radar sensor and set to 5 [dB] in the case of a tilted radar sensor.

Sensor Type

Radac brings two types of radar sensors to the market, the Stainless Steel radar and the ATEX certified EX radar. Both radars require a different offset value that accounts for the internal path-length of the radar signal and the difference in geometry. Selecting the right sensor type means that the right reference is used for measuring the distance between the radar and the water surface.

Heave Source

With three radars available it is possible to select one of the three radars to supply its data to the algorithm for calculating all non-directional parameters (i.e. wave height and period). The radar that is used for measuring non directional parameters is called the 'Heave Source'.

Reflection diagram

The reflection diagram gives a snapshot of raw radar data in the frequency domain. The reflection diagram provides a useful insight in the quality of the reflection signal that is obtained by the radar.

After changing the sensor parameters for the three radar sensors, rebooting the system is required for the changes to take effect. The reflection diagram of each sensor should be checked to ensure that the water level measurement is within the defined limits (More information can be found in 'Step 4.2: Check the Reflection Diagrams').

Step 4. Perform a system check

This section explains how to inspect the quality of measurements after configuring and rebooting the WaveGuide processing unit (the start-up process can take up to 5 minutes):

Step 4.1: Check the system information page

The system information table can be reached through the status menu item on the right top. The system info page displays the communication status (as shown in Fig. 3.7). A communication status "INIT" indicates that the WaveGuide processing unit is initiating the communication process with the radar sensors. Once the communication process is initiated (a process that can take up to five minutes after reboot) the displayed status becomes 'OK'.

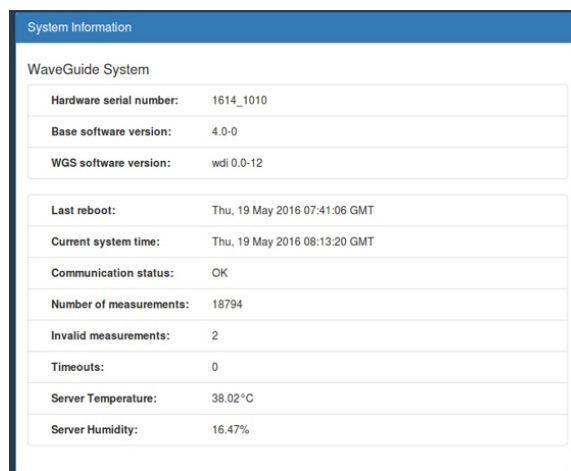

System Information	
WaveGuide System	
Hardware serial number:	1614_1010
Base software version:	4.0-0
WGS software version:	wdi 0.0-12
Last reboot:	Thu, 19 May 2016 07:41:06 GMT
Current system time:	Thu, 19 May 2016 08:13:20 GMT
Communication status:	OK
Number of measurements:	18794
Invalid measurements:	2
Timeouts:	0
Server Temperature:	38.02°C
Server Humidity:	16.47%

Figure 3.7: System information.

In the same table, the ratio between the number of performed and invalid measurements gives an indication of the system performance. When the system is set up in a correct manner, the number of invalid measurements should be below 10% of the number of performed measurements. However, during the start up and communication initiation processes the number of invalid measurements can grow to over 1000 (temporarily increasing the ratio between invalid measurements and performed measurements). The number of invalid measurements will show a slow increase after the initial invalid measurements.

Step 4.2: Check the reflection diagrams

The reflection diagram for each radar sensor can be accessed via the sensor configuration page by clicking on the corresponding "reflection" button (Fig. 3.8).

A reflection diagram is a graphic representation of a 25 [ms] scan, where the signal strength [dB] is plotted against the measurement distance [m]. A scan consists of one up-sweep (increasing frequency, blue curve) and one down-sweep (decreasing frequency, red curve).

Often several peaks are visible in a reflection diagram as shown in Fig. 3.8. This is caused by the multiple signal reflections between radar, water surface and any objects within the radar foot-print. The leftmost peak is generated by the so called internal reflection.

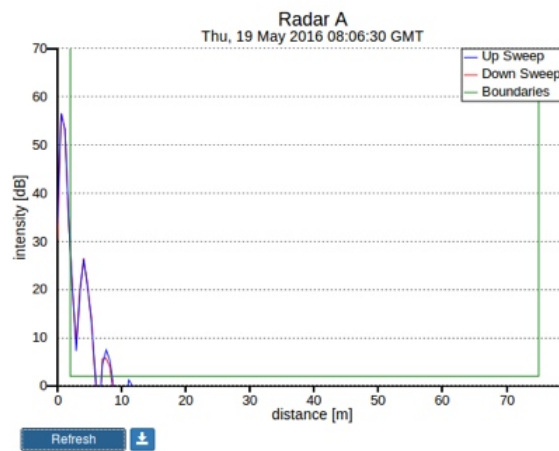

Figure 3.8: The reflection diagram of one of the three sensors.

Based on the defined range maximum and minimum values, the WaveGuide system shows the applied boundaries using vertical green lines. A horizontal green line shows the minimum accepted reflection strength (the value set as the Signal Minimum [dB] parameter). The three green lines together form a region in which a measurement is accepted, and any result outside of it is ignored.

Step 4.3: Check the measurements

On the 'Dashboard' page, the heave parameter shows data measured during the last 1, 3 or 10 minutes. Please inspect the available heave and slope graphs to visually confirm the measured data. From the same menu all calculated parameters are available. Please take into account that it can take up to 10 minutes to gather enough raw data to calculate the parameters.

Step 5. Configure the distribution of data

The WaveGuide processing unit can transmit measured and calculated data via its serial ports (COM1 & COM2) and distribute data over the network to several addresses at the same time. In the 'Subscriptions' page under 'Configuration'(Fig. 3.9 and Fig. 3.10), the

existing subscriptions can be removed or modified and new ones can be added. Simultaneous subscriptions are possible.

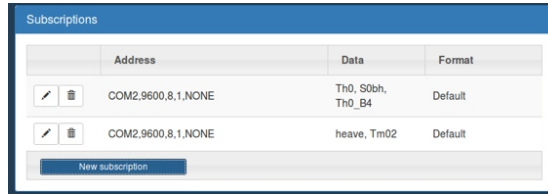

Figure 3.9: List of defined subscriptions.

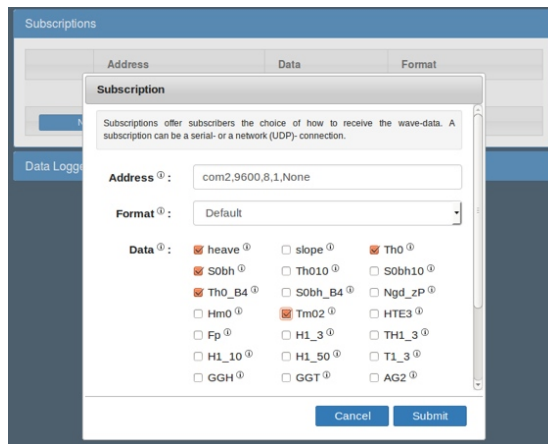

Figure 3.10: Subscriptions dialog.

The address for a serial port subscription should have the following format: 'port', 'baud-rate', 'number of data bits', 'number of stop bits', 'parity', 'handshake'. For example the default values are, COM2,9600,8,1,NONE,NONE.

If the address string is not complete the default values will be used. For example, COM2,9600 will be interpreted as COM2,9600,8,1,NONE,NONE.

The format for the network message is: 'http://ip.address:port'. For example, http://192.168.111.103:8032.

The format of the output string can be chosen from the drop-down menu. Four message format options are available, Default, Format01, Format02 and Format03.

After modifying or creating a new subscription, click the 'update' button and authorize the changes. This will change and store the settings and implement the subscription with immediate effect (no system reboot is required).

Default message format

The Default format starts a new line for each parameter in the subscription. The time used in the Radac format is Unix Epoch time in milliseconds (UTC time in milliseconds since 00:00:00 on the 1st of January 1970). Each line in the Default format ends with a Line-Feed character (char10). When a parameter is disapproved or not available the string 'NaN' is inserted instead of the actual value (NaN stands for Not a Number). An example of the output strings in the Radac format is:

```
time=1157359800206;sensor=radcan;H1=-319.9429cm;
time=1157359259847;sensor=radcan;Hm0=1.2517135cm;
time=1157359860268;sensor=radcan;H1=NaNcm;
```

Format01 message format

Modifications can be made upon request. For example, the Korean Meteorological Administration (KMA format) preferred a readable time format in the Korean time zone. An example of the output strings in the KMA format is:

```
time=2006/09/04 17:58:00;H1=-319.70026cm;
time=2006/09/04 17:48:59;Hm0=1.3314528cm;
time=2006/09/04 17:59:00;H1=NaNcm;
```

Format02 message format

The Format02 message, formerly called the SESAM format, used by the Dutch Ministry of Infrastructure and the Environment (Rijkswaterstaat), is only defined for the heave and the 10 second mean (H parameter). It consists of 8 character lines (Line-Feed character + status character + sign character + 4 character value in cm + Carriage-Return character). For a regular message the status character is a space. If an error occurs the status character becomes a letter A. An example of the output strings in the RWS format is,

```
+0001
- 0004
A+9999
```

Format03 message format

The Format03 message, formerly called the FGTI format, is used by the Belgium government. Where one string is used for all required information (parameters + spectrum) per processing interval. The chosen parameters are separated by a semicolon (;) and the 51 spectrum values (czz10) are included. The 'NaN' string is replaced with a '-9999' string. An example of the output string in the FGTI format is:

```
time=1159898219628;sensor=radcan;H1/3=0.101608045cm;Hm0=0.070818946cm;Czz10=0.0,5.0869432E-5,
1.3970293E-4,4.7124052E-4,7.1615004E-4,7.975558E-4,7.6214876E-4,7.1647903E-4,7.6107396E-4,6.847791E-
4,6.6441507E-4,4.567583E-4,7.3393347E-4,8.3342794E-4,7.177321E-4,8.320104E-4,9.631133E-4,4.7024636E-
4,5.479116E-4,7.0798665E-4,7.973897E-4,8.964213E-4,0.0010354978,5.15721E-4,8.0113555E-4,8.009798E-4,
8.0272334E-4,8.0752687E-4,6.5126666E-4,8.172201E-4,5.1516114E-4,6.2683446E-4,5.63858E-4,3.5074513E-4,
6.5980386E-4,5.53472E-4,7.269641E-4,6.289437E-4,6.156702E-4,5.8503065E-4,6.2185246E-4,5.5198127E-4,
4.41777E-4,2.7770927E-4,3.3221033E-4,7.5746316E-4,6.8937184E-4,6.167301E-4,7.730603E-4,6.513776E-4,
5.5705215E-4cm2/Hz;
```

Chapter 4

Using the system

4.1 Calculated parameters

Once the system is commissioned the facilities of data presentation, reflection diagram, system info etc. can be used to monitor the proper operation of the system.

Water level and wave height information are calculated using the measurements of one radar (the heave source). For directional information the measurements of all three radars are analysed and the directional parameters are calculated. There are two analysis routines:

Wave analysis

The Standard Wave Processing Package (SWAP) is used in performing time and frequency domain analysis on the measured data to calculate wave parameters. This package is the standard processing package used by the Dutch government for wave height analysis. It also meets the standards set by the International Association of Oil & Gas Producers (OGP). A detailed description of the SWAP package is available on the Radac website (<http://www.radac.nl>).

The SWAP parameters are calculated every minute using 20 minute data blocks. The 20 minute observation block is chosen as a compromise between short enough to obtain "small" variance in the statistical parameters and long enough to assume it to be a stationary process. The time stamp used on SWAP parameters is the mean between the start and end time of the 20 minute data block.

Tide analysis

The tide parameters H10, H5 and H1 are calculated by averaging measured data over 10 [min], 5 [min] and 1 [min] periods respectively.

Each parameter receives a time stamp central to the block of data that was used for its calculation. The spectra and parameters that can be calculated by the WaveGuide system are described in Appendix 1. Due to the large number of parameters, only a selection of the most commonly used ones is displayed on the user interface. This selection can be modified by Radac upon request.

4.2 Data logging

A USB storage device can be easily mounted to the WaveGuide processing unit for data logging. It needs to be said that without taking additional precautions, USB storage is not a safe method for archiving data. Since power failures can damage USB devices, it is advised to use an Uninterrupted Power Supply (UPS) together with a high quality USB device. Having said this, usb storage provides a great backup option while sending data out over a serial or network connection.

The WaveGuide processing unit supports FAT32 , Ext2 and Ext3 formats. The majority of USB devices is delivered with FAT32 format.

Note

The USB device used must not be formatted using NTFS.

A USB drive must be manually mounted when first used, and will be automatically re-mounted on system reboot. Mounting a USB drive can be done via the push buttons on the front panel of the WaveGuide processing unit. Use the right arrow button to scroll to the storage menu. If the message 'Disk not mounted' is displayed, click the down button. If the message 'Mount USB disk? OK' is displayed, click OK to mount the device.

To unmount or remove the disk safely, use the right arrow button to scroll to the storage menu. Then click the down button to arrive at the "Safely remove? OK" option. Clicking the OK button safely unmounts the device.

The 'Data Logger' page in the web user interface (Fig. 4.1) gives access to the stored data. Also the data can be transferred easily to other computers using an FTP program. Login name and password for FTP file transfers are the same as the user-name and password for modifying settings (by default both user-name and password are 'radac')

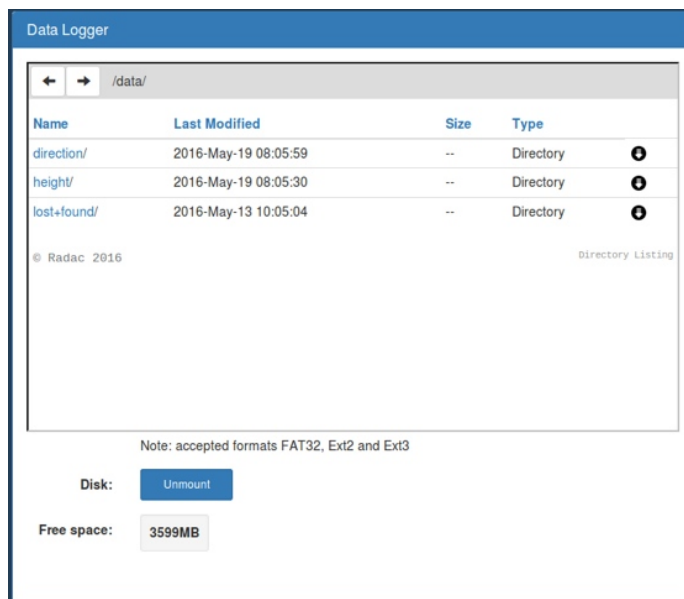

Figure 4.1: Data logger page.

The folder structure used is one directory per system. In this directory, sub-directories are created that contain the raw data and parameter files (one file per day per parameter).

If the drive is full, a delete mechanism starts. This allows the system to store the most recent parameters at the expense of the oldest data.

Appendix 1: System parameters

Default parameters

In the web user interface a selection of the raw and processed parameters is by default made available to the user (Table 1).

Name	Description	Unit
heave	Instantaneous water level	<i>cm</i>
slopeX	Instantaneous water slope in x-direction	–
slopeY	Instantaneous water slope in y-direction	–
heaveAVG	Instantaneous water level averaged over all three radars	<i>cm</i>
Th0	Average mean direction in the frequency band 30-500mHz	<i>deg</i>
S0bh	Average directional spreading in the frequency band 30-500mHz	<i>deg</i>
Th010	10 mHz spectrum of mean direction	<i>deg</i>
S0bh10	10 mHz spectrum of directional spreading	<i>deg</i>
Th0_B4	Mean direction of the directional distribution in the B4 frequency band	<i>deg</i>
S0bh_B4	Average width of the directional distribution in the B4 frequency band	<i>deg</i>
Ngd_zP	Percentage of datapoints that do not contain error code before pre-processing	%
Hm0	Significant wave height from M0	<i>cm</i>
Tm02	Average period from M0 and M2 in the range $f=[30-500]$ mHz	<i>s</i>
HTE3	Wave height from TE3 (band energy from Czz10(f) where $f=[30-100]$ mHz)	<i>cm</i>
Fp	Frequency f where Czz10(f) has its maximum in the range $f=[30-500]$ mHz	<i>mHz</i>
H1/3	Average height of the highest 1/3 of the waves	<i>cm</i>
TH1/3	Average period of the highest 1/3 of the waves	<i>s</i>
H1/10	Average height of the highest 1/10 of the waves	<i>cm</i>
H1/50	Average height of the highest 1/50 of the waves	<i>cm</i>
T1/3	Average period of the longest 1/3 of the periods	<i>s</i>
GGH	Average height of all waves	<i>cm</i>
GGT	Average period of all waves	<i>s</i>
AG2	Number of waves	–
SPGH	Standard deviation of the wave height	<i>cm</i>
SPGT	Standard deviation of the wave period	<i>s</i>
Hmax	Height of highest wave	<i>cm</i>
Tmax	Period of longest wave	<i>s</i>
THmax	Period of highest wave	<i>s</i>
HCM	Crest height, maximum positive value of all data within one analysis period	<i>cm</i>
Czz10	10 mHz energy density spectrum	<i>cm</i>
H1	Average height over last 1 minute	<i>cm</i>
H5	Average height over last 5 minutes	<i>cm</i>
H10	Average height over last 10 minutes	<i>cm</i>

Table 1: Default parameters

All possible parameters

Tables 2 to 11, describe all the parameters measured and calculated by the WaveGuide Direction.

Changing the parameters available by default on the web-interface is possible. It is strongly recommended that the user requests the changes when the WaveGuide Direction is ordered so that all necessary tests can be performed at Radac. Post-installation adjustments to the available parameters are also possible upon request.

Name	Description	Unit
heave	Instantaneous water level	<i>cm</i>
slope	Water surface slopes	–

Table 2: Raw data at 2 or 2.56 [Hz]

Name	Description	Unit
Czz5	5 mHz energy density spectrum	<i>mHz</i>
WTBH	Table of wave heights	<i>cm</i>
WTBT	Table of wave periods	<i>s</i>
Czz10	10 mHz energy density spectrum	<i>mHz</i>

Table 3: Spectra and wave tables

Name	Description	Unit
Hm0	Significant wave height from M0	<i>cm</i>
M0	Band energy from Czz10(f) in the range $f = [30-500]$ mHz	<i>cm²</i>
M0_M	Band energy from Czz10(f) in the range $f = [30-1000]$ mHz	<i>cm²</i>
Hm0_M	Significant wave height from M0_M	<i>cm</i>
Tm02	Average period from M0 and M2 in the range $f = [30-500]$ mHz	<i>s</i>
Tm02_M	Average period from M0 and M2 in the range $f = [30-1000]$ mHz	<i>s</i>
TE0	Band energy from Czz10(f) in the range $f = [500-1000]$ mHz	<i>cm²</i>
TE1	Band energy from Czz10(f) in the range $f = [200-500]$ mHz	<i>cm²</i>
TE1_M	Band energy from Czz10(f) in the range $f = [200-1000]$ mHz	<i>cm²</i>
TE2	Band energy from Czz10(f) in the range $f = [100-200]$ mHz	<i>cm²</i>
HTE3	Wave height from TE3 (band energy from Czz10(f) where $f = [30-100]$ mHz)	<i>cm</i>
Fp	Frequency f where Czz10(f) has its maximum in the range $f = [30-500]$ mHz	<i>mHz</i>
Fp_M	Frequency f where Czz10(f) has its maximum in the range $f = [30-1000]$ mHz	<i>mHz</i>
AV10_H	Theoretical number of degrees of freedom of the energy density spectrum (= $4 * \text{Ndlr_H}$) 20 HS7 Wave height from band energy from Czz5(f) in the range $f = [30-142.5]$ mHz	<i>cm</i>
Tm0_1	Minus first moment period from M-1 and M0 in the range $f = [30-500]$ mHz	<i>s</i>
Tm0_1_M	Minus first moment period from M-1 and M0 in the range $f = [30-1000]$ mHz	<i>s</i>

Table 4: Parameters of spectral processing

Name	Description	Unit
H1/3	Average height of the highest 1/3 of the waves	cm
TH1/3	Average period of the highest 1/3 of the waves	s
H1/10	Average height of the highest 1/10 of the waves	cm
H1/50	Average height of the highest 1/50 of the waves	cm
T1/3	Average period of the longest 1/3 of the periods	s
GGH	Average height of all waves	cm
GGT	Average period of all waves	s
AG2	Number of waves	–
SPGH	Standard deviation of the wave height	cm
SPGT	Standard deviation of the wave period	s
Hmax	Height of highest wave	cm
Tmax	Period of longest wave	s
THmax	Period of highest wave	s
HCM	Crest height, maximum positive value of all data within one analysis period	cm

Table 5: Parameters from time domain processing of data collected in the last 20 [min]

Name	Description	Unit
Nwt_zP	Sum of periods of waves divided by analysis period	–
Ndlr_H	Number of valid sub-series of the signal in the vertical direction	–
Ngd_zP	Percentage of data-points that do not contain error code before pre-processing	–
Nu_z	Number of valid data-points that are rejected because of 0-sigma errors	–
Nv_z	number of valid data-points that are rejected because of 4-sigma errors	–
Nd_z	number of valid data-points that are rejected because of 4-delta errors	–
Ni_z	number of interpolated or extrapolated vertical wave motion datapoints	–

Table 6: Quality parameters

Name	Description	Unit
H	Average height over last 10 seconds	cm
H1	Average height over last 1 minute	cm
H5	Average height over last 5 minutes	cm
H10	Average height over last 10 minutes	cm

Table 7: parameters from tide processing

Name	Description	Unit
Th010	10 mHz spectrum of mean direction	deg
S0bh10	10 mHz spectrum of directional spreading	deg

Table 8: Directional spectra

Name	Description	Unit
Th0	Average mean direction in the frequency band 30-500mHz	deg
S0bh	Average directional spreading in the frequency band 30-500mHz	deg
Th3	Average mean direction in the frequency band 30-100mHz	deg

Table 9: Directional parameters

In the directional spectral analysis the frequency range from 30-500mHz is divided in 15 separate frequency bands. These frequency bands are given in the Table 10.

Name	Description	Unit
B0	30-500	<i>mHz</i>
B1	200-500	<i>mHz</i>
B2	100-200	<i>mHz</i>
B3	30-100	<i>mHz</i>
B4	Peak frequency band ($f_{max}-\Delta f$ to $f_{max}+\Delta f$)	<i>mHz</i>
G1	30-45	<i>mHz</i>
G2	45-60	<i>mHz</i>
G3	60-85	<i>mHz</i>
G4	85-100	<i>mHz</i>
G5	100-125	<i>mHz</i>
G6	125-165	<i>mHz</i>
G7	165-200	<i>mHz</i>
G8	200-250	<i>mHz</i>
G9	250-335	<i>mHz</i>
G10	335-500	<i>mHz</i>

Table 10: Frequency bands from 5 [mHz] spectra

Per frequency band 7 parameters are calculated. These parameters are given in Table 11.

Name	Description	Unit
Hm0_	Average wave height in the frequency band	<i>m</i>
Ndfe_	Number of degrees in the frequency band	<i>deg</i>
Th0_	Mean direction of the directional distribution in the frequency band	<i>deg</i>
S0bh_	Average width of the directional distribution in the frequency band	<i>deg</i>
G1_	Average asymmetry of the directional distribution in the frequency band	–
G2_	Average flatness of the directional distribution in the frequency band	–
Fm01_	Average frequency in the frequency band	<i>mHz</i>

Table 11: Parameters in each of the 15 frequency bands

Appendix 2: System specifications

WaveGuide radar

Mechanical

Dimensions	26.5 x 26 [cm] (diameter, height)
Weight	≈ 12 [kg]
Casing material	Stainless Steel

Electrical

Radar frequency	9.9 – 10.2 [GHz]
Modulation	Triangular FMCW
Emission	The emitted microwave energy is far below acceptable limits for exposure of the human body. Depending on the type of antenna, a maximum radiation of 0.1 [mW] is generated.
Power requirements	24-64 [VDC] and 6 [Watt] (when powered separately from processing unit).

Environmental conditions

Ambient temperature	-40 to 60 [°C]
Relative humidity	0 – 100 %
Ingress protection	IP67

WaveGuide processing unit

Dimensions	170 x 172 x 85 [mm] (depth x width x height) 19" rack mounting available on request
Processor	ARM Cortex™ A9 792MHz
Radar connection	3 x RS485 serial port
Serial data export	2 x RS232 (COM1 and COM2)
Network data export	3 x Ethernet port for configuration, data viewing and data export
Power requirements	24-48 [VDC] and 22.8 [Watt] if radars are powered via processing unit 12-48 [VDC] and 4.8 [Watt] if the processing unit has no radars connected
Operating temperature	-40 to 65 [°C]
Cooling	No fan required
Display	2 x 20 characters
Memory	On board flash

General system specifications

sampling rate	5 [Hz]
wave heights	0 – 60 [m]
wave periods	0 – 1 [Hz]
accuracy water level	< 1 [cm]
processing period:	
wave height	20 [min] (SWAP standard)
wave direction	20 [min] (SWAP standard)
tide	1, 5 and 10 [min])
processing interval:	
wave height	moving window, all parameters refreshed every 1 minute
wave direction	moving window, all parameters refreshed every 1 minute
tide	moving window, all parameters refreshed every 1 minute