



WaveGuide - Water Level

Ex. Certified

User Manual

WaveGuide - Water Level

Ex. Certified

User Manual

Applicable for systems part no.
WG-WL67-EX
WG-WL19-EX

Version 3.1
17th of Mar. 2015



Radac B.V.
Elektronicaweg 16b,
2628 XG Delft,
The Netherlands.
tel: +31(0)15 890 3203
e-mail: info@radac.nl
website: www.radac.nl



Preface

This user manual and technical documentation is intended for engineers and technicians involved in the software and hardware setup of the Ex. certified version of the WaveGuide Water Level system.

Note

All connections to the instrument must be made with shielded cables with exception of the mains. The shielding must be grounded in the cable gland or in the terminal compartment on both ends of the cable. For more information regarding wiring and cable specifications, please refer to Chapter 2.

Legal aspects

The mechanical and electrical installation shall only be carried out by trained personnel with knowledge of the local requirements and regulations for installation of explosion-proof equipment in hazardous areas.

The information in this installation guide is the copyright property of Radac BV.

Radac BV disclaims any responsibility for personal injury or damage to equipment caused by:

- Deviation from any of the prescribed procedures.
- Execution of activities that are not prescribed.
- Neglect of the general safety precautions for handling tools and use of electricity.

The contents, descriptions and specifications in this installation guide are subject to change without notice. Radac BV accepts no responsibility for any errors that may appear in this installation guide.

Additional information

Please do not hesitate to contact Radac or its representative if you require additional information.

Contents

Preface

Introduction	1
1 Radar positioning and installation	3
1.1 Safety notes	3
1.2 Positioning	4
1.3 Installation	5
2 Wiring	6
2.1 WaveGuide radar	6
2.2 WaveGuide server	7
2.3 Separate radar power supply	8
3 WaveGuide system commissioning	9
Step 1. Connect the WaveGuide server to a computer	10
Step 2. Become an authorized user	11
Step 3. Enable expert mode	11
Step 4. Set sensor parameters	12
Step 5: Perform a system check	13
Step 6: Set system date and time.	15
Step 7: Configure the distribution of data	16
4 Using the system	18
4.1 Calculated parameters	18
4.2 Data logging	18
Appendix 1: System parameters	20
Appendix 2: System specifications	21

Introduction

The WaveGuide Water Level system is a highly accurate water and tide level gauge which is compact, robust and easy to install.

The WaveGuide Water Level system consists of:

- An Ex. Certified WaveGuide radar mounted above water level.
- A WaveGuide server installed in a control room or a terminal box.

The WaveGuide radar is a low power X-band radar that measures the distance between the water surface and the radar antenna with an accuracy of < 1 [cm]. The resulting information is passed to the WaveGuide server for processing and analysis.

The WaveGuide server collects the measured data from the WaveGuide radar unit, performs the necessary data analysis and provides water level and tide information on both a physical user interface and a web-based interface. The WaveGuide server also facilitates data storage and data broadcasting.

This manual describes the Ex. version of the WaveGuide Water Level system.

Warning

Do not use the instrument for anything else than its intended purpose.

This manual consists of 4 chapters. Chapter 1, specifies the radar positioning criteria for optimal measurement quality. Chapter 2, illustrates the mounting and installation procedure. Chapter 3, describes the commissioning of the system via the user interface. Chapter 4, explains data processing, data presentation and data distribution within the system.

Please refer to Appendix 1, for a list of measured and calculated parameters. And to Appendix 2, for specifications, information about certification and environmental conditions applicable to the WaveGuide Water Level Ex. Certified version.

Chapter 1

Radar positioning and installation

1.1 Safety notes

The personnel installing the WaveGuide system must have basic technical skills to be able to safely install the equipment. When the WaveGuide system is installed in a hazardous area, the personnel must work in accordance with the (local) requirements for electrical equipment in hazardous areas.

Caution

Modification to the instrument may only be carried out by trained personnel that are authorized by Radac BV. Failure to adhere to this will invalidate the approval certificate.

Warning

In hazardous areas it is compulsory to use personal protection and safety gear such as: hard hat, fire-resistive overall, safety shoes, safety glasses and working gloves.

Avoid possible generation of static electricity.

Use non-sparking tools and explosion-proof testers.

Make sure no dangerous quantities of combustible gas mixtures are present in the working area.

Never start working before the work permit has been signed by all parties.

Warning

Make sure that all power to the instrument is switched off before opening the covers of the WaveGuide radar. Failure to do so may cause danger to persons or damage the equipment.

All covers of the WaveGuide radar must be closed before switching on the power.

Caution

Before opening the cover of the Waveguide Radar, make sure that the blocking device is removed.

Use a 3 [mm] Allen key.

Caution

Do not damage the thread of covers and WaveGuide radar housing and keep the thread free of dirt. After opening, grease it lightly with anti seize grease.

When closing, never tighten the covers before the threads are properly engaged. The covers should be turned counter-clockwise until the thread clicks in place, then turn clockwise until the covers are fully closed.

After closing the covers, do not forget to place the blocking devices.

1.2 Positioning

For obtaining the best results from a WaveGuide Water Level system a number of radar positioning criteria must be taken into account:

- It is advised to choose a mounting position such that the WaveGuide radar beam is free of large reflecting obstacles (the beam of the F08 antenna can be approximated to a conical shape having a 5° [deg] half top angle as shown in Fig. 1.1). The minimum horizontal distance between a radar and any obstacle in the beam's path should be at least 10% of the vertical distance between the radar and the obstacle. This does not only include horizontal objects in the beam's path but also vertical structures.
- Any structure that the WaveGuide radar is mounted to might have some influence on the water flow around it. Hence, it is advised to mount the radar at a position facing the mean flow direction so that the radar can measure the least disturbed water surface.
- The reference level for the mounting height of the radar is shown in Fig. 1.1.
- Figure 1.2, shows the polarization plane of the signal emitted from the radar antenna. If the WaveGuide radar is mounted close to a large vertical wall, then the radar should be mounted such that the polarization plane is parallel to the wall. That is to minimize the effect of the wall on the propagation of the signal. Nevertheless, the horizontal distance between the radar and the wall should comply with the previous criteria.
- A vertically mounted radar (0° [deg] tilt angle) results in optimal performance. But if necessary the WaveGuide radar can be mounted with a maximum tilt angle of 15° [deg] (tilted to face the direction away from the structure it is mounted on).

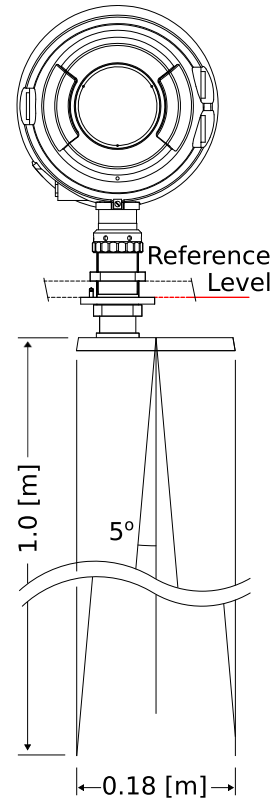

Figure 1.1: The 5° [deg] half top angle of the F08 antenna beam and the reference level for mounting height measurement.

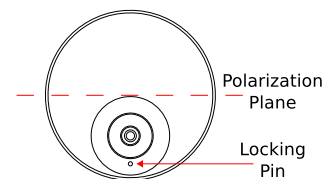

Figure 1.2: Top view of radar antenna and its polarization plane.

1.3 Installation

To facilitate the mounting of the WaveGuide radar, an optional mounting plate is available upon request (Part no. WG-MP-EX). Figure 1.3 shows a sketch of the optional mounting plate and its dimensions.

The mounting plate can be fixed to two horizontal beams (Fig. 1.4). The length of the beams must take into account the minimum horizontal distance between the WaveGuide radar and any obstacles in the path of the radar signal (as explained in the radar positioning criteria). Each beam must have 2 holes either 200 or 270 [mm] apart depending on the intended orientation of the mounting plate.

It is advised to mount the horizontal beams first. Then to attach the mounting plate to the horizontal beams and finally to mount the WaveGuide radar to the mounting plate. Mounting the radar is done by mounting the radar antenna to the mounting plate and then mounting the radar housing to the antenna.

Radac can provide an optional dual-purpose wrench/spanner (Part no. WG-EX-tool). One end of the wrench (Fig. 1.5) is an open-end wrench that can be used to tighten the antenna to the mounting plate. While the other end is a pin wrench that can be used for tightening the radar housing to the antenna.

Upon request, Radac can supply an optional frame (Part no. WG-MH-EX) that allows for mounting the WaveGuide radar and mounting plate at angles 0, 5, 10, 15 and 20 [deg] away from vertical (see Fig.1.6). The radar mounting plate (Part no. WG-MP-EX) is included with this frame as well as brackets to allow mounting the frame to a handrail.

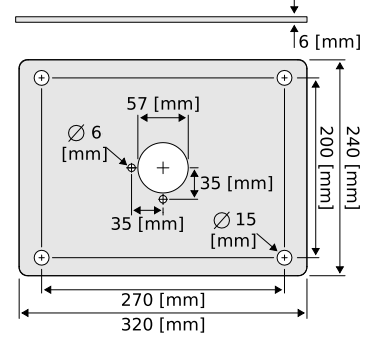

Figure 1.3: Optional mounting plate for the WaveGuide radar (Part no. WG-MP-EX).

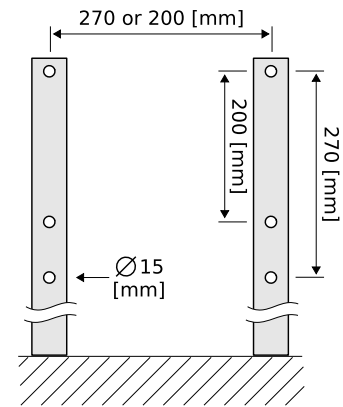

Figure 1.4: Top view of the horizontal mounting beams.

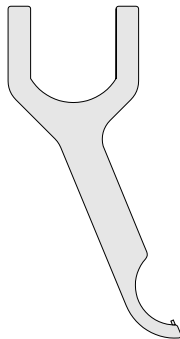

Figure 1.5: Optional wrench that allows mounting of the WaveGuide radar (Part no. WG-EX-tool).

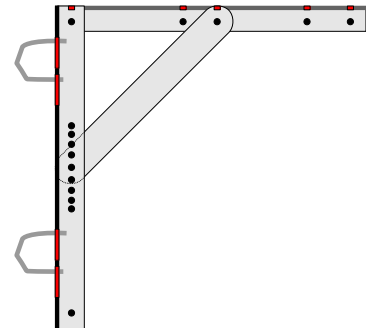

Figure 1.6: Optional frame that allows mounting of the WaveGuide radar at different angles (Part no. WG-MH-EX).

Chapter 2

Wiring

2.1 WaveGuide radar

An explosion proof increased safety (Ex-e) cable gland is supplied with each WaveGuide radar for use on the terminal compartment as a watertight cable entry point. The supplied gland allows the installation of non-armoured elastomer and plastic insulated cables from 7.5 to 11.9 [mm] in diameter.

In the terminal compartment there is a gray connector block as shown in Fig. 2.1. This connector block is used to connect the RS485 data wires (poles labeled 1, 2 and 3) and supply power to the radar (poles labeled + and -).

The length of the cable used to connect the WaveGuide radar to the WaveGuide server can not exceed 1200 [m].

The cable used must be shielded and the shielding must be connected to ground at both ends of the cable. Since there can be a potential difference between the ground at the radar and the ground at the server, a capacitor (10 to 100 [nF]) should be used on one side of the cable between its shield and the ground.

The cable used must contain at least one twisted pair of wires for use with the RS485 data signal (poles labeled 1 and 2). In addition, the cable must contain one wire for the signal ground (pole labeled 3) and two wires for supplying power from the WaveGuide server to the WaveGuide radar (poles labeled + and -).

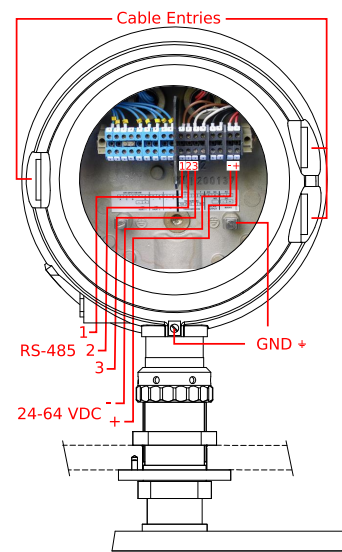

Figure 2.1: WaveGuide radar terminal compartment.

Warning

Improper installation of cable glands or stopping plugs will invalidate the Ex. approval of the WaveGuide radar.

The housing of the WaveGuide radar has two interconnected ground connections. One in the terminal compartment and one on the outside of the housing.

Warning

Safety depends on proper grounding. Check the resistance of the ground connection directly after installation. The measured ground resistance shall be below the maximum prescribed by local grounding requirements.

2.2 WaveGuide server

For ease of use, the connector poles common between the WaveGuide server and radar are marked using the same labeling symbols.

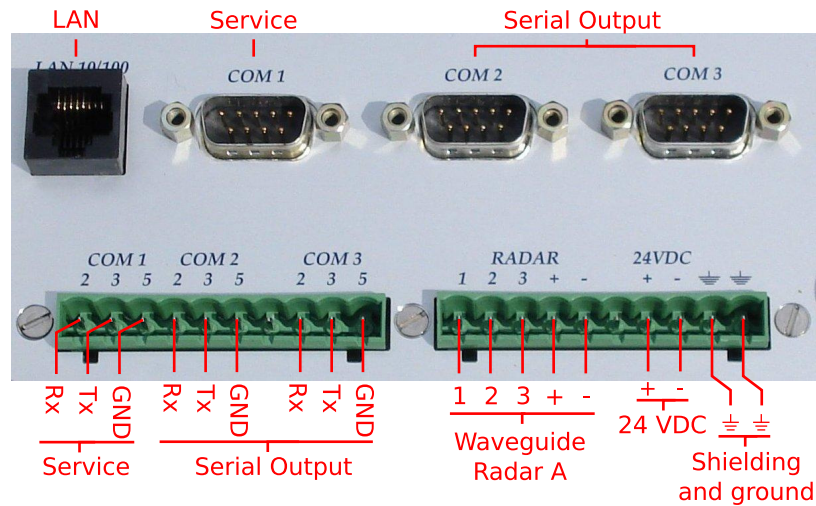

Figure 2.2: Connector panel on the WaveGuide server.

In addition to the connectors used for connecting the WaveGuide radar, the connector panel of the WaveGuide server includes the following connectors,

- COM1: Reserved service port.
- COM2: Serial port for data output via a RS-232 connection.
- COM3: Serial port for data output via a RS-232 connection.
- LAN port: Ethernet access to the server.

Note

Each COM port is connected in parallel to both the DE-9 connector and the terminal block connector. Hence, only one of the two types of connectors needs to be used per COM port.

When the radar is powered through the server, then the power supply for the server must be 24-36 [VDC]. Please do take care of the voltage drop due to wire resistance between the server and the radar. The power supply to the WaveGuide radar is controlled by the power switch on the WaveGuide server.

2.3 Separate radar power supply

In some cases it is more convenient to use a separate power supply to power the WaveGuide radar (as shown in Fig. 2.3) rather than supplying it with power from the server side (as shown in Fig. 2.4). In that case a 24-64 [VDC] power supply can be used on the WaveGuide radar side to supply it with 6 [Watt] of power.

If a separate power supply is used for the WaveGuide radar, then the cable used to connect the WaveGuide server to the WaveGuide radar does not need the extra two wires for power. In that case, three wires in the cable between the WaveGuide server and radar will be sufficient (one twisted pair and a signal ground wire).

In the case that a separate power supply is used to power the radar, then the server can be supplied with a power supply of 9-36 [VDC].

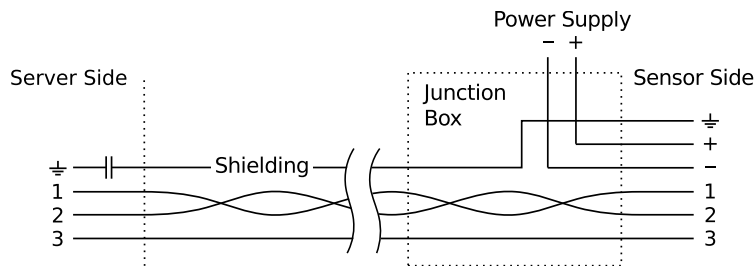

Figure 2.3: Diagram showing connection between the WaveGuide server and radar when radar is powered separately from server.

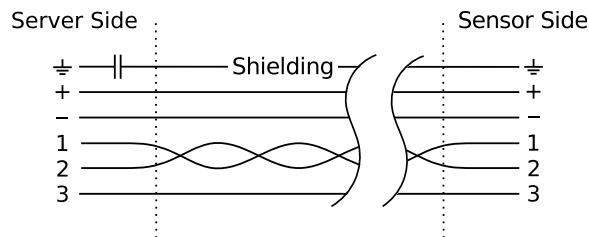

Figure 2.4: Diagram showing connection between the WaveGuide server and radar when radar is powered by server.

Chapter 3

WaveGuide system commissioning

With all the wiring in place as described in the previous chapter, the server can be configured using the following steps (explained in the current chapter):

1. Connect the WaveGuide server to a computer.
2. Become an authorized user.
3. Enable expert mode.
4. Set radar sensor parameters
5. Perform a system check.
6. Set system date/time.
7. Configure the distribution of data.

The display on the server shows system information and measured parameters and is controlled using,

- Button 1: To switch between groups.
- Button 2: To switch between items within each group.
- Button 5: To confirm mounting and unmounting of USB data storage.

The server display contains the following groups and items:

- Parameters
 - Scrolls through selected parameters (Appendix 1, Table 1)
- Network
 - Host name
 - IP address
- System information
 - Date and time
 - Uptime
 - Software version
- USB storage (only appears when USB device is connected)
 - State
 - Mount USB disk?/ Unmount USB disk?

Step 1. Connect the WaveGuide server to a computer

Once the WaveGuide server is connected to a Local-Area-Network, communication with the WaveGuide server can be done via the available web-interface (Fig. 3.1). For this purpose any web browser with JavaScript enabled can be used.



Figure 3.1: The web interface of the WaveGuide server.

Note

A computer can be connected to the WaveGuide server directly using a network cable (a crossover cable is not required).

By default, during startup the WaveGuide server tries to obtain an IP-address by searching the Local-Area-Network for a DHCP server. If a DHCP server is not found, the WaveGuide server will use the default IP-address 192.168.111.71.

When the WaveGuide server completes the startup process, its IP-address can be found via the LCD display (it can take up to 10 minutes for the IP-address to appear). To view the IP-address, scroll through the menu using button 1 until network information is displayed and then use button 2 to switch between displaying the Host-Name and the IP-address.

The default IP-address can be modified via the web interface. To access the web-interface, type the IP-address indicated on the LCD display (e.g. <http://192.168.111.71>) in the address line of your Internet browser. Note, that your computer must be on the same IP-address subnet as the WaveGuide server that you are trying to connect to.

Link	Description
Measurements	Measured data plots.
Parameters	Calculated parameter plots.
Spectra	Not applicable for Water Level systems.
Data logger	Access to optional data logger files.
Sensor raw data	Preview of raw data required for data processing routines.
Configure Sensor	For defining the sensor configuration and mounting height.
Subscriptions	Settings for data distribution.
Configure Network	Allows the user to change the network settings.
Set Date/Time	WaveGuide server date and time settings.
Expert Mode	Allows for editing more settings.
System Info	System state overview.

Table 3.1: Description of server links.

Step 2. Become an authorized user

To modify the WaveGuide system configuration you need to be an authorized user. Therefore, an authorization dialogue will appear when the user tries to change a configuration item.

The authorization will become invalid after 5 minutes of inactivity. However, the web browser may store the login name and password. In that case, the authorization data will be submitted automatically by the browser without a pop-up dialog. The default login name and password are both “radac”.

After successful authorization, the changed settings will be stored and a reboot dialog will appear. The settings will not be effective until the WaveGuide server is rebooted.

Step 3. Enable expert mode

For some settings extra caution is required as changing them can lead to system malfunctioning. Such settings are hidden from the regular menus and can be accessed by enabling the expert mode.

The expert mode can be enabled by clicking the "enable" button on the "Expert Mode" page. This will cause an authorization dialog to appear (please refer to Step 2 for information about authorization). After a successful authorization process a list is displayed that indicates that the "Expert mode is enabled" (Fig. 3.2).



Figure 3.2: The "Expert Mode" link displays the expert mode "Enable" button. Enabling the expert mode requires authorization.

Step 4. Set sensor parameters

The "Configure Sensor" link will display a sensor drop-down menu. Choose "radcan" and click the "edit" button, this will display the configuration page for the radar sensor (Fig. 3.3).

Note

For normal operation, do not change the sensor "Name", "Sample rate", "Sweep size", "Antenna offset" or "Stilling well pipe diameter".

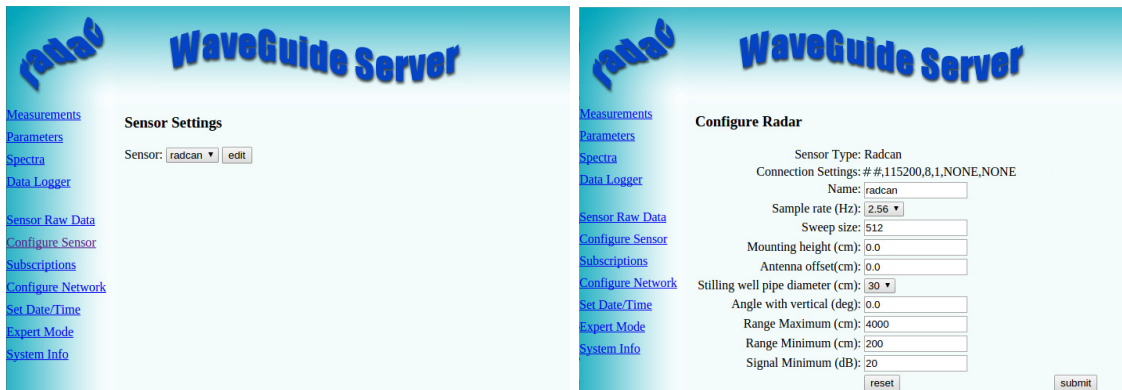

Figure 3.3: The "configure sensor" page will display a sensor drop-down menu. Choose "radcan" and click "edit", this will display the configuration page for the radar sensor.

The "Mounting height" is defined as the height of a radar above the reference water level in [cm]. The reference point for measuring the height of each radar sensor is the lower-side of the radar mounting plate (see Fig. 1.1). By default, the mounting height is set to zero [cm].

The tilt angle of the WaveGuide radar, or the "Angle with vertical", is measured in [deg] and by default is set to zero [deg].

The "Range Maximum" is the maximum distance in meters, at which the radar will detect the water level. It is advised (but not necessary) to set this parameter to a value lower than two times the distance from the radar to the lowest expected water level. This is to avoid detecting multiple echoes of the same measurement sweep.

The "Range Minimum" is the minimum distance in meters, at which the radar will detect the water level. This parameter is used to avoid spurious measurements and should be set depending on the installation location. If there are any nearby surfaces that can reflect the radar signal, the "Range Minimum" should be set to a value higher than the distance to those reflecting surfaces. The "Range Minimum" parameter must not be lower than 2.0 [m] to avoid interference with the internal reflection in the radar antenna.

The "Signal Minimum" is the lower limit for the signal power that will be considered in water level measurements. This parameter should be set to 20 [dB] in the case of a vertically mounted radar and set to 5 [dB] in the case of a tilted radar.

Rebooting the system is required after changing the radar sensor parameters for the changes to take effect. The reflection diagram of the radar should be checked to ensure that the water level measurement is within the defined limits (More information can be found in "Step 5.2: Check the raw sensor data").

Step 5: Perform a system check

This section explains how to inspect the quality of measurements after configuring and rebooting the WaveGuide server (the start-up process can take up to 5 minutes):

Step 5.1: Check the system Info page

The bottom most table on the system info page, displays the radar status (as shown in Fig. 3.4). The communication status "INIT" indicates that the WaveGuide server is initiating the communication data stream from the WaveGuide radar. Once a communication process is initiated the displayed status becomes "OK".

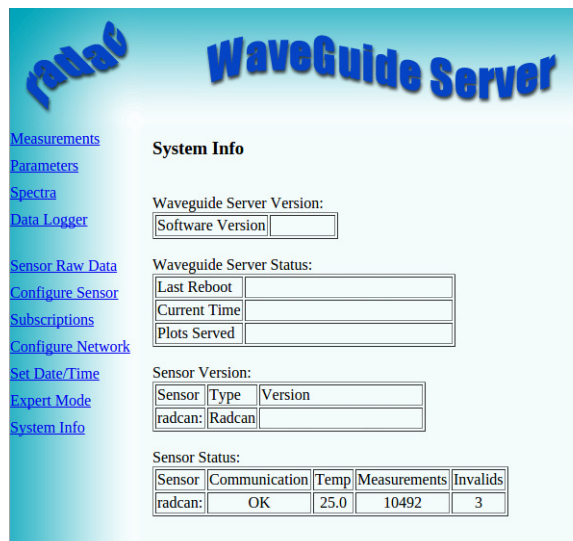

Figure 3.4: System information.

In the same table, the ratio between the number of performed and invalid measurements gives an indication of the system performance. When the system is setup in a correct manner, the number of invalid measurements should be below 10% of the number of performed measurements. However, during the startup and communication initiation processes the number of invalid measurements can grow to over 1000 (temporarily increasing the ratio between invalid measurements and performed measurements). After the initial invalid measurements the increase in the number of invalid measurements will be very limited.

Step 5.2: Check the raw radar data

The reflection diagram for the radar sensor can be accessed via the "Sensor Raw Data" link by selecting "Radcan" and clicking on the "Request" button (Fig. 3.5).

A reflection diagram is a graphic representation of a 25 [ms] scan, where the signal strength [dB] is plotted against the measured distance [m]. A scan consists of one up-sweep (increasing frequency, red curve) and one down-sweep (decreasing frequency, blue curve).

It is normal to have several peaks in a reflection diagram (as shown in Fig. 3.5). Those peaks do not affect the performance of the system and are caused by the multiple signal reflections between the radar, the water surface and any objects within the radar's footprint.

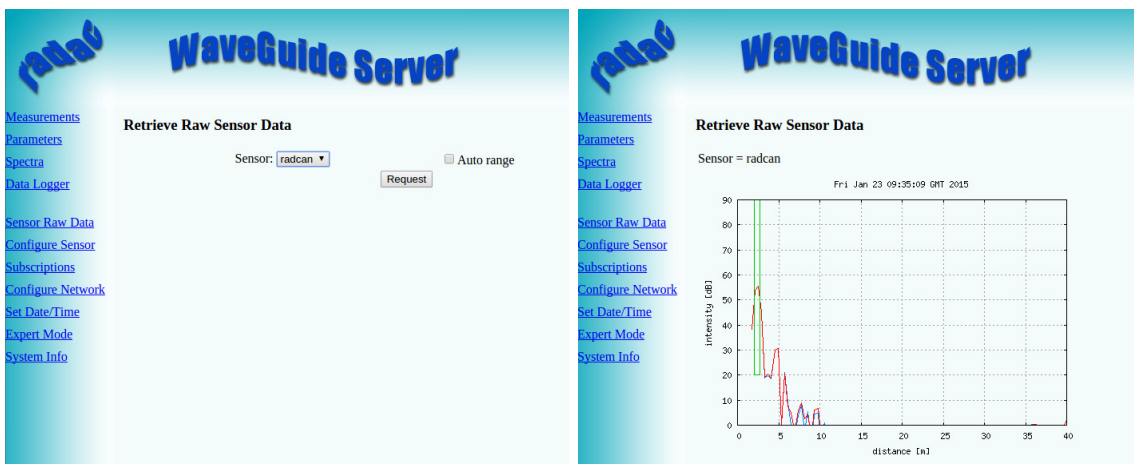

Figure 3.5: The "Sensor Raw Data" page and the reflection diagram of the radar sensor.

Based on a one minute history of measured water level, the WaveGuide system calculates an expected minimum and maximum water level for the next measurement. The values for the expected minimum and maximum levels are shown on the reflection diagram using vertical green lines. A horizontal green line shows the minimum expected reflection strength (the value set as the Signal Minimum [dB] parameter).

The three green lines together form a region of acceptable values for the current measurement and any values outside of it are ignored. The highest peak in the region bounded by the green lines, is considered to represent the distance to the water surface. The region of acceptable values is automatically updated when persistent reflections occur outside this region.

Step 5.3: Check measurements

On the "Measurements" page, the data measured during the last 1, 3 or 10 minutes can be viewed. Please inspect the available graphs to visually confirm measured heave data.

Step 6: Set system date and time.

Some customers choose to use their own facilities to log the time at which data points are collected. However, for the highest level of accuracy the WaveGuide server is capable of adding time stamps to measured data points.

The current date and time can be set using the "Set Date/Time" page (Fig. 3.6). The date and time are kept by an on-board clock (with battery back-up). Please be aware that such on-board clocks are not very accurate and can drift over the years while the system is used.

If the system is connected to a network and has access to the Internet, then it will automatically synchronize the time and date with an Internet time server. It is advised to set the initial date and time as accurately as possible. Because the automated time adjustment uses small incremental steps. As a result it can take a considerable amount of time to correct a large time difference. After changing the system time or date, the WaveGuide server must be rebooted.

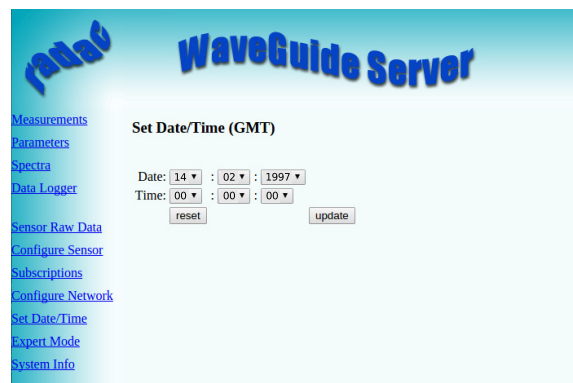

Figure 3.6: Setting the system time and date.

If the WaveGuide system is not connected to the Internet but instead connected to a local network that includes a time server, then the WaveGuide server can be adjusted to synchronize time and date with the local time server. For more information regarding such an adjustment please contact Radac.

Step 7: Configure the distribution of data

The WaveGuide server can transmit measured and calculated data via its serial ports (COM2 and COM3) and via its network link to several network addresses. In the "Subscriptions" page (Fig. 3.7), the existing subscriptions can be removed or modified and new ones can be added. Simultaneous subscriptions are possible.

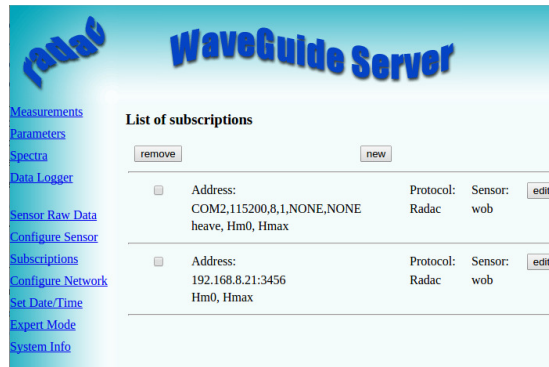

Figure 3.7: Example list of defined subscriptions.

The address for a serial port subscription should have the following format: "port", "baud-rate", "number of data bits", "number of stop bits", "parity", "handshake". For example, COM2,9600,7,1,EVEN,NONE.

If the address string is not complete the default values will be used. For example, COM2,9600 will be interpreted as COM2,9600,8,1,NONE,NONE.

The format for a network port address is: "http://ip address:port". For example, http://192.168.111.103:8032.

The format of the output string can be chosen from the drop-down menu. Four message format options are available, Radac (default), KMA, SESAM and FGTI.

After modifying or creating a new subscription, click the "update" button and authorize the changes. This will change and store the settings and implement the subscription (no system reboot is required).

Radac message format

The Radac format starts a new line for each parameter in the subscription. The time used in the Radac format is Unix Epoch time in milliseconds (UTC time in milliseconds since 00:00:00 on the 1st of January 1970). Each line in the Radac format starts with a Carriage-Return character (char13) and ends with a Line-Feed character (char10). When a parameter is disapproved or not available the string "NaN" is inserted instead of the actual value (NaN stands for Not a Number). An example of the output strings in the Radac format is,

```
time=1157359800206;sensor=radcan;H1=-319.9429cm;  
time=1157359259847;sensor=radcan;Hm0=1.2517135cm;  
time=1157359860268;sensor=radcan;H1=NaNcm;
```

KMA message format

Modifications can be made upon request. For example, the Korean Meteorological Administration (KMA format) preferred a readable time format in the Korean time zone. An example of the output strings in the KMA format is,

```
time=2006/09/04 17:58:00;H1=-319.70026cm;  
time=2006/09/04 17:48:59;Hm0=1.3314528cm;  
time=2006/09/04 17:59:00;H1=NaNcm;
```

SESAM message format

The SESAM format, used by the Dutch Ministry of Infrastructure and the Environment (Rijkswaterstaat), is only defined for the heave and the 10 second mean (H parameter). It consists of 8 character lines (Line-Feed character + status character + sign character + 4 character value in cm + Carriage-Return character). For a regular message the status character is a space. If an error occurs the status character becomes a letter A. An example of the output strings in the RWS format is,

```
+0001  
- 0004  
A+9999
```

Chapter 4

Using the system

4.1 Calculated parameters

Once the system is commissioned the facilities of raw data presentation, reflection diagram, system info etc. can be used to monitor the proper operation of the system.

The instantaneous water level information is available in the form of heave. Which, can be found on both the "Measurements" page of the systems web interface and the physical user interface.

Average water level is calculated by averaging the radars measurements over periods of 10 [sec], 1, 5 or 10 [min] (parameters H, H1, H5, and H10 consecutively). A representation of the water level variation is available in the form of the parameter Hm0 which is the standard deviation of the heave measurements over a 20 minutes period.

All parameters that are calculated over a time period get a time stamp that is in the center of the time period used to calculate them. The calculated parameters can be viewed on both the "Parameters" page of the systems web interface and the physical user interface.

The selection of parameters that are displayed on the user interface can be modified by Radac upon request.

4.2 Data logging

When ordering a WaveGuide system it is possible to request an optional USB connector on the server side. Such a connector allows a USB storage device to be easily mounted to the WaveGuide server for easy data logging. But without taking additional precautions, USB storage is not a safe method for archiving data. Since power failures can damage USB devices, it is advised to use an Uninterrupted Power Supply (UPS) together with a high quality USB device.

The WaveGuide server supports FAT32 , Ext2 and Ext3 formats. The majority of USB devices are delivered with FAT32 format.

Note

The USB device used must not be formatted using NTFS.

A USB drive must be manually mounted when first used, and will be automatically re-mounted on system reboot. Mounting a USB drive can be done via the push buttons on the front panel of the WaveGuide server. Using button "1" scroll to the storage menu. If the message "Disk not mounted" is displayed click button "2". If the message "Mount USB disk? OK" is displayed. Click button "5" to mount the device.

To unmount or remove the disk safely, use button "1" to scroll to the storage menu. Then click button "2" to arrive at the "Safely remove? OK" option. Then Click button "5" to unmount the device.

The "Data Logger" page in the web user interface (Fig. 4.1) gives access to the stored data. Also the data can be transferred easily to other computers using an FTP application. Login name and password for FTP file transfers are the same as the user-name and password for modifying settings (by default both user-name and password are "radac").



Figure 4.1: Data logger page.

The folder structure used is one directory per system. In this directory, sub-directories are created that contain the raw data and parameter files (one file per day per parameter).

If the drive is full, a delete mechanism starts. This allows the system to store the most recent parameters at the expense of the oldest data.

Appendix 1: System parameters

Table 1, describes all the parameters measured and calculated by the WaveGuide Water Level system.

Name	Description	Unit
heave	Instantaneous water level raw data at 2 or 2.56 [Hz]	<i>cm</i>
Ngd_zP	Percentage of data points that do not contain error code before pre-processing	%
H	Average height over last 10 seconds	<i>cm</i>
H1	Average height over last 1 minute	<i>cm</i>
H5	Average height over last 5 minutes	<i>cm</i>
H10	Average height over last 10 minutes	<i>cm</i>
Hm0	4 x the standard deviation of water level during lats 20 minutes	<i>cm</i>

Table 1: Default parameters

Appendix 2: System specifications

WaveGuide radar

Mechanical

Dimensions	26 x 44 [cm] (width, height)
Weight	≈ 14 [kg]
Casing material	Chromatized aluminum

Electrical

Radar frequency	9.9 – 10.2 [GHz]
Modulation	Triangular FMCW
Emission	The emitted microwave energy is far below acceptable limits for exposure of the human body. Depending on the type of antenna, a maximum radiation of 0.1 [mW] is generated.
Power requirements	24-64 [VDC] and 6 [Watt] (when powered separately from server).

Environmental conditions

Ambient temperature	-40 to 60 [°C]
Relative humidity	0 – 100 %
Ingress protection	IP67
Safety	Explosion proof: ATEX II 1/2 GD T80°C EEx d IIB T4 Class I, Division 1, Groups C and D, acc. to ANSI/NFPA 70 (FM, CSA)

WaveGuide server

Dimensions	IP67 (GENE) 19 x 19 x 18 [cm] (width, height and depth). IP67 (TITAN) 19 x 19 x 13 [cm] (width, height and depth). 19" (GENE) 48 x 9 x 28 [cm] (width, height and depth). 19" (TITAN) 48 x 9 x 21 [cm] (width, height and depth).
Computer boards	AAEON, GENE-TC05. Eurotech, TITAN.
Processor	Intel® Atom™ E620T 600MHz (GENE). Marvell® XScale PXA270™ RISC 520MHz (TITAN).
COM ports	1 x RS485 (used to connect the radar). 3 x RS232.
Network	Ethernet
Power req. GENE	24-36 [VDC] and 12 [Watt] if radar is powered via server. 9-36 [VDC] and 6 [Watt] if radar is powered separately.
Power req. TITAN	24-36 [VDC] and 8 [Watt] if radar is powered via server. 9-36 [VDC] and 2 [Watt] if radar is powered separately.
Operating temperature	-40 to 85 [°C]
Cooling	No fan required
Display	2 x 20 characters
Memory	On board flash
Protection class	IP67 (optional)

General system specifications

Sampling rate 2.56 [Hz]

Measurement range 2 - 75 [m]

Water level accuracy < 1 [cm]

Part Number:

WG-WL19-EX for a 19" rack server and an Ex. certified radar

WG-WL67-EX for a IP67 server and an Ex. certified radar